Masters Theses

Student Theses and Dissertations

1950

Efficiency studies of the effect of moisture on the power consumption of mine scrapers

Georges J. Vigier

Follow this and additional works at: https://scholarsmine.mst.edu/masters_theses



Part of the [Mining Engineering Commons](#)

Department: Mining and Nuclear Engineering

Recommended Citation

Vigier, Georges J., "Efficiency studies of the effect of moisture on the power consumption of mine scrapers" (1950). *Masters Theses*. 6677.

https://scholarsmine.mst.edu/masters_theses/6677

This thesis is brought to you by Scholars' Mine, a service of the Curtis Laws Wilson Library at Missouri University of Science and Technology. This work is protected by U. S. Copyright Law. Unauthorized use including reproduction for redistribution requires the permission of the copyright holder. For more information, please contact scholarsmine@mst.edu.

EFFICIENCY STUDIES OF THE EFFECT OF MOISTURE ON
THE POWER CONSUMPTION OF MINE SCRAPERS

BY

GEORGES J. VIGIER

A

THESIS

submitted to the faculty of the
SCHOOL OF MINES AND METALLURGY OF THE UNIVERSITY OF MISSOURI
in partial fulfillment of the work required for the
Degree of
MASTER OF SCIENCE, MINING ENGINEERING
Rolla, Missouri
1950

Approved by

J. D. Forester

Professor of Mining Engineering

ACKNOWLEDGEMENT

The writer wishes to express all his indebtedness to Dr. J. D. Forrester, Chairman of the Department of Mining Engineering, for his assistance in providing the author with a Research Fellowship without which the completion of this work would not have been possible and for all he did to make this year spent in the United States a very interesting and enriching experience to the author. Special acknowledgement is also made to him for his consultation, and for his suggestions in the preparation of this thesis.

CONTENTS

	Page
Acknowledgment	ii
List of Illustrations	iv
List of Tables	iv
List of Graphs	iv
Introduction	1
Review of Literature	2
History of Scraping	2
Scraper Operation Data	3
Motive Power	5
Scraper Hoists Assemblies	10
Design of Scrapers	10
Efficiency of scrapers	12
Apparatus for Scraper Tests	14
Equipment Used in Tests	14
Material Tested	17
Method of Collecting Data	17
Application of the Principle of Similitude	22
Description of Model Scraper Tests	25
Box Type Scraper Tests	28
Crescent Type Scraper Tests	36
How Tests May Help to Chose the Best Operating Conditions	36
Conclusions Drawn from Study of Model Scrapers	51
Summary of Scraper Tests	52
Appendix	54
Bibliography	60
Vita	62

LIST OF ILLUSTRATIONS

Fig.		Page
1.	Photograph of Box Scraper	16
2.	Photograph of Crescent Scraper	18
3.	Photograph of Recording Wattmeter	19
4.	Hoist-wattmeter Wiring Diagram	20
5.	Wattmeter Chart of Model Scraper Tests	21
6.	Costs Representation	47
7.	Costs Representation	48
8.	Costs Representation	50

LIST OF TABLES

Data on Scraper Transportation	6
--	---

LIST OF GRAPHS

1. Box Scraper - Power Consumption - 126 fpm	29
2. Box Scraper - Power Consumption - 191 fpm	30
3. Box Scraper - Power Consumption - 252 fpm	31
4. Box Scraper - Capacity - 126 fpm	33
5. Box Scraper - Capacity - 191 fpm.	34
6. Box Scraper - Capacity - 252 fpm.	35
7. Crescent Scraper - Power Consumption - 126 fpm.	37
8. Crescent Scraper - Power Consumption - 191 fpm.	38
9. Crescent Scraper - Power Consumption - 252 fpm.	39
10. Crescent Scraper - Capacity - 120 fpm	40 & 41
11. Crescent Scraper - Capacity - 191 fpm	42
12. Crescent Scraper - Capacity - 252 fpm	43

INTRODUCTION

Many years of practice have resulted in the standardization of several types of scrapers which are now commonly manufactured for use in mining. Although experience has brought out much information on scraping operations, no systematic studies of the efficiency of mine scrapers have been carried out before the experimental works done in the last few years at Missouri School of Mines and Metallurgy.^(1,2,3)

-
- (1) Forrester, J.D. and Clayton, A.B., A Study of Mine Scraper Buckets and Their Efficiency, Missouri School of Mines and Metallurgy, Technical Bulletin, Vol. 17, No. 2, 1946, 48 pp.
 - (2) Forrester, J.D., and Carmichael, R.C., The Effect of Rope Speed and Moisture on the Use of Scrapers in Mining, Missouri School of Mines and Metallurgy, Technical Bulletin, Vol. 18, No. 1, 1947, 31 pp.
 - (3) Johnsen, S.F., A Study of the Power Consumption of Mine Scrapers, A Thesis Submitted to the Faculty of Missouri School of Mines and Metallurgy, 1949, 62 pp.
-

Purpose of Problem:

The purpose of this present study is to consider the effect which moisture in the muck has on the efficiency as regards power consumption and amount of material scraped, of different types of mine scrapers. Scraper weight, rope speed, and moisture content were the variables considered for each scraper type.

Problem Procedure:

Two kinds of scrapers were tested, namely: The box scraper and the crescent scraper. They were available in the mining laboratory.

The model scrapers were constructed at a scale of 1 to 6.

A small electrically-driven hoist was used to pull the buckets on a 15 foot-long table. A Westinghouse watt-meter connected with the electric motor graphically recorded the power consumed.

The weight of material scraped after a given number of passes was determined. The power consumed was computed from the graphic registration of the wattmeter.

REVIEW OF LITERATURE

History of Scraping:

(4)

According to Van Barneveld power scrapers were first used

(4) Van Barneveld, Charles E., Mechanical Underground Loading in Metal Mines, Co-op. Work of U.S. Bureau of Mines and Missouri School of Mines and Metallurgy, 1924, pp. 210-11.

for moving mine muck by the Bunker Hill and Sullivan Mining Company, at Kellogg, Idaho, in 1898. A small single-drum air hoist powered a slip scraper which was guided and pulled back to the muck by hand.

Slip scrapers were used until 1921, but the development of two drum hoists and bottomless scrapers began before World War I and resulted in a great increase of efficiency over that work yielded by the single-drum, slip scraper.

The greatest, early field of application of scraping practice in mining took place in the Lake Superior iron and copper districts and, since 1936, scraping has been used importantly in the Tri-State Mining District of Missouri, Kansas and Oklahoma.

Developments in the past twenty years have been characterized by increases in horse-power, in rope speed, and in weights of buckets together with the common adoption of three-drum hoists.

An abstract of the history of scraper practice has been given
(5)
by Forrester and Clayton.

(5) Forrester and Clayton, op. cit. pp. 1-4.

Scraper Operation Data:

Briefly, the field of application of power scrapers may be classified as follows:

Development work.

Inclined shafts

Drifts and cross-cuts

Production stopes.

Top slicing stopes

Open stopes

Room and pillar stopes

Sub-level caving stopes

Cut and fill stopes

Glory-hole or mill-hole stopes

Square-set stopes

Shrinkage stopes

Block-caving stopes

Filling stopes with waste and tailing

Transfer of material in sub-levels

Open-pit mining

Placer mining

(6)

According to Jackson and Hedges, scrapers are best adapted

- (6) Jackson, Chas. F., and Hedges, J.H., Metal Mining Practice. U. S. Bureau of Mines, Bulletin No. 419, 1939, p. 183.

to underground use where large quantities of ore must be moved comparatively short distances.

(7)

Peele states that scrapers are very well suited to excavat-

- (7) Peele, Robert, Mining Engineers' Handbook, Third Edition, John Wiley and Sons, pp. 27, 11 and 12.

ing very thin coal seams where cost of removing roof or floor material to permit use of mobile loaders would be prohibitive.

The main factors affecting efficiency are summarized as follows

(8)

by Jeppe:

- (8) Jeppe, C.B., Gold Mining on the Witwatersrand. The Trans Vaal Chamber of Mines, Volume I, 1946, p. 889.

- a. Size of scoop.
- b. Speed of rope.
- c. Amount of delays due to broken ropes and other inevitable repairs.
- d. Stopping width, concentration of rocks, length of drag.
- e. Position of scraper lines.

(9)

Pierce and Bryan bring out the advantages of scrapers over

- (9) Pierce, R. V., and Bryan, R.N., Scraping and Loading in Mines. Compressed Air Magazine, Vol. 47, No. 6, June 1942, pp. 6750-4.

other types of loading machines: For example,

- a. Operation of a mechanical scraper is very simple and does not necessitate a long education plan.
- b. Initial cost is less than that of other loading and conveying machinery.
- c. It is not complex and has few exposed parts.
- d. The bucket and rope of the unit usually are the only parts exposed to possible roof falls, thus, the whole scraper installation is less liable to damage than are other common loading devices.
- e. It accommodates more diversified types of mining conditions.
- f. Men need stay in untimbered areas but a fraction of the total working time.

Motive Power:

(10)
Johnsen gives detailed data on scraper hoists.

(10) Johnsen, S. F., op. cit. pp. 5-17.

The trend during the past 25 years has been toward the use of larger, more powerful scraper hoists capable of pulling heavier loads at higher speeds. Overpowered hoists are desirable for scraper work, as they are commonly subjected to rough use and frequent momentary overloading, and, though the first cost is higher, maintenance is considerably less.

Table 1 presents data on a few operations and is quoted after
(11)
Jackson and Hedges. They state, too, that for long drags, the

(11) Jackson and Hedges, op. cit. pp. 185-6.

TABLE 1.

Data on Scraper Transportation

Type of Ore	Hoist		Details of Scraper				Scraping Distance feet	Remarks
	Horse Power	Rope Speed ft. per Min.	Type	Width Inches	Weight lbs.	Approximate Load		
Soft iron ore	15	225	Box	34	—	10 cu. ft.	100 max.	Level pull to raises
" " "	15	240-280	"	48	—	18 cu. ft.	60-150	Level pull to raises, max. load, rate 60 tons/hour.
Hard and soft iron, some chunks	15	240-280	Hoe	42	—	9 cu. ft.	125 max	Pull down 30°-35° slope.
Hard, chunk rock and soft iron ore	25	230	semi-hoe	54	900	18 cu. ft.	50-150	25 tons/hour mucking into large cans
Large blocks of Zn ore in dolomite gangue	25	200 high 144 low		72	2660	2,000 lbs.	400 max.	Pull down 20° slope, 50 tons/manshift, including oper., helpers, repairmen
Coarse and fine copper-bearing conglomerate	35	—	Hoe	48	1500	13 cu. ft.	150 max.	100 tons/shift loading cars on level.
Very hard ore, large angular blocks	60	—	Hoe	80	2800	10,000 lbs.	150 max.	In scraper drifts — 500 tons/8 hours.
Iron ore, large slabs	55	130-150	Box with Teeth	48	3100	6,500 lbs.	200 max.	Aver. 300 tons/shift loading into cars.
Hard, blocky magnetite	25	200	Hoe	48	1400	2240 lbs.	330 max. 189 av.	27.3 tons-manshift scraping to cars.
Large, heavy,	150	190 return 174 pull	Hoe	84	3600	7,600 lbs.	100 max. 75 av.	96 tons/hour on transfer level. Actual time operating, 60%

more efficient practice is to employ a two-speed hoist, wherein the low speed is used for digging and the high speed for dragging. They add that the data compiled in Table 1 were collected in 1932 and that since that time considerably higher speeds have been adopted. For example, 350 fpm is now common, and in some mines speeds of 450 fpm for pulling the load and 650 fpm for returning the empty scraper have been tried successfully.

Scraper hoists are powered by electric or compressed-air motors.

Air Hoists: Piston and turbine motors are employed. Turbine motors are faster but are more apt to freeze than the piston types which, on the other hand, consume more air. Generally electric motors are preferred. Jackson and Hedges⁽¹²⁾ justify the preference

(12) Jackson and Hedges, op. cit., p. 185.

from the standpoint of power consumption. In actual practice, the air-operated hoist requires six or eight times as much primary power as the electrically driven one.

(13)
Matson has presented figures comparing costs of scraping

(13) Matson, R.C., Scraping Practice in the Michigan Iron Mines of the Lake Superior District, Michigan College of Mining and Technology, Bulletin 4, Vol. 2, 1929, p. 75.

with air and electric hoists. For instance he cites cases where 604,005 tons of ore were scraped with air hoists at a power cost of \$0.0346 per ton and where 91,124 tons of ore were moved with electric hoists at a power cost of \$0.0042 per ton; a ratio of about 8 to 1.

However, Jackson and Hedges ⁽¹⁴⁾ and Matson ⁽¹⁵⁾ credit air

(14) Jackson and Hedges, op. cit., p. 187.

(15) Matson, R.C., op. cit., pp. 51-52.

hoists with certain advantages. They are, (1) the cooling and ventilating effect of exhaust, (2) a better control of the speed of the air motors by the throttle control, (3) if overloaded, air hoists stall without damaging the motor, (4) show less susceptibility to be damaged by moisture than electric motors, (5) better safety in gaseous coal mines.

Electric hoists: As previously stated, cost of power is lower for an electric motor than for air-driven hoists. Although power cost is not as important as some other items in the total cost of scraping operation it is an interesting feature. Jackson and Hedges ⁽¹⁶⁾ give two examples to demonstrate the proportionate costs

(16) Jackson and Hedges, op. cit., p. 187.

of various items involved in operating electrically driven hoists.

	Gents per Ton
Labor	5.27
Rope	1.43
Repairs and renewals including sheaves	1.86
Power	0.69

In this example, the scraper weighed 1,760 pounds and had a capacity of 1 ton of ore. The average scraping distance was 175 feet, the maximum being 400 feet.

At another mine, the cost of loading in drift headings with scrapers and slide and 25-horsepower electric hoist was divided as

follows:

	Cost per Ton
Labor	\$0.0500
Maintenance (exclud. rope).	0.0572
Rope	0.0263
Power	0.0160

(17)

Other advantages of electric hoists are cited by Johnsen.

(17) Johnsen, S.F., op. cit., pp. 13-14.

For example, they show: (1) better efficiency (65% as against 15% for air hoists), (2) an ability to supply any demand of power, (3) better safety due to less noise of operation.

Both A.C. and D.C. motors have been used for powering scrapers. The earlier installations were generally composed of D.C. motors directly connected to the haulage wires. However, the numerous advantages of A.C. motors succeeded in making them used to an ever greater extent. The common advantages of A.C. motors over the D.C. type are: less line losses, lower first and maintenance cost of A.C. line and motors, better ability to withstand overload, no commutation troubles or danger of burning armatures.

Appropriate equipment allows a good control of the speed of an A.C. motor. This is obtained by adjusting the amount of resistance placed in series with the secondary or rotor winding of the motor. This adjustment is accomplished magnetically through a bank of grid resistors, regulated by a multipoint master controller which also provides for reversal of the motor. 60 cycle, 440 to 550 volt current is now common although some older installations still operate under voltages of around 220.

Scraper-Hoist Assemblies:

A wide range in sizes of hoists as well as of buckets exist today. For instance, Ingersoll-Rand ⁽¹⁸⁾ manufactures more than 440

(18) Ingersoll Rand, Modern Methods for Scraper Mucking and Loading. 1939, pp. 157-172.

sizes and types of hoists.

Large hoist-ramp assemblies are often mounted on track wheels, or in other cases, hoist and scraper-ramp are mounted on caterpillar treads. Portable scraper-hoist outfits are also available.

Double-drum hoists are presently more numerous than three-drum hoists, but the use of the three-drum hoists is increasing. They have proved their convenience in wide stopes where a lateral movement of the scraper is very useful and desirable, and also in pillar recovery where slushing is not limited to one direction.

Design of Scrapers:

Three types of scrapers have become standardized in practice. (1) the hoe scraper, (2) the box scraper, and (3) the crescent scraper. Modifications may be made, as desired, by adding side plates or teeth. Teeth often are useful when slabbed material has to be moved.

An important consideration is the digging angle of the scraper. That is, it is the angle that the cutting edge of the scraper blade makes with the muck pile when the rope is under maximum tension. According to Van Barneveld ⁽¹⁹⁾ the theoretical maximum digging effect

(19) Van Barneveld, Charles E., op. cit., p. 225.

of a scraper would occur when the plane of the cutting edge lies in the resultant of the pull and of the force of gravity. With these theoretical considerations, he deduces that the best digging angle is 30 degrees. However, experience has shown that digging angles of 45 to 50 degrees generally fit best any condition of work.

A forward curvature at the top of the blade, or a baffle plate fastened to the top of the blade, is often provided to prevent the scraper from digging after it is loaded.

Scrapers must have a balance which properly favors their digging and riding characteristics. This is obtained by using long and heavy bails which must rest on the ground, and by a judicious distribution of counterweights. Scrapers must be of rugged construction. Special alloys of manganese, chrome, molybdenum and nickel steels are commonly used in their fabrication.

(20)

Forrester and Clayton have drawn the following conclusions

(20) Forrester and Clayton, op. cit., pp. 31-33.

from their studies:

1. There is a weight where the scraper reaches its maximum effectiveness for a given rock size.
2. The bail must slightly overbalance the rear of the scraper.
3. For moving finely divided material the scrapers tested rank in the following order: crescent, slope bail hoe, straight bail hoe, and box.

4. For intermediate rock sizes the scrapers rank in the following order: slope bail hoe, straight bail hoe, crescent and box.

5. For very coarse material the straight bail hoe is the only scraper applicable.

6. A baffle plate at the top of the scraper blade helps prevent the scraper from continuing to dig after it has a full load.

Efficiency of Scrapers:

(21)
Forrester and Carmichael have studied the effect of rope

(21) Forrester and Carmichael, op. cit., pp. 14-23.

speed on scraper efficiency. Their conclusions are:

1. The flow of the muck pile during operation of the hoe scrapers can be utilized as a contributing factor to scraper efficiency.

2. The efficiency of a given scraper is at a maximum at a definite rope speed for any size of material.

3. The hoe scrapers are less affected by variations in rope speed than either the box or crescent scrapers.

4. The decline in scraper efficiency beyond the optimum speed is so gradual that the saving in time might outweigh the loss in efficiency at higher speeds.

(22)
Johnsen in his studies has been chiefly concerned with power

(22) Johnsen, op. cit., pp. 29-51.

consumption. He concluded as follows:

1. Inasmuch as the efficiency of a given scraper varies with the weight of the scraper, the efficiency is at a maximum at a def-

inite weight.

2. Variations in efficiencies between lighter weight scrapers are greater than the variations between the heavier ones. Therefore, too much weight is better than too little.

3. The efficiency of any scraper is at a maximum at a definite rope speed. For all types except the straight bail hoe scraper, the optimum rope speed is about 340 feet a minute; the straight bail hoe operates best at 250 fpm.

4. The amount of rock scraped per pass does not necessarily establish the best operating conditions for a given scraper. These conditions can be determined only after a coordinated study of the amount of rock scraped and the amount of power consumed.

(23)
Johnsen reports, too, that the efficiency of a scraper, as

(23) Johnsen, op. cit., pp. 33-34.

far as load capacity is concerned, gradually declines when worked beyond the optimum speed but that up to a certain point the saving in time with higher speeds would overbalance the small drop in scraper capacity. His power consumption tests showed that to be true for the lighter weights. Nevertheless, when more weights were added to the scrapers, the majority of the tests showed a progressive increase in efficiency as the rope speeds were increased. The capacity of each scraper load gradually decreased during Johnsen's tests but the time saving was enough to affect lower power consumption per given weight of rock scraped.

Effect of Moisture:

(24) Forrester and Carmichael and (25) Johnsen have studied the

(24) Forrester and Carmichael, op. cit., p. 14.

(25) Johnsen, op. cit., p. 34.

effect of moisture on the efficiency of the different types of scrapers for a specific rope speed (120 fpm). Only one weight was tested for each scraper. Discrepancies exist between their conclusions. Forrester and Carmichael state that the efficiency of a given scraper is at a maximum at a definite moisture content, whereas Johnsen states that addition of moisture does not increase scraper efficiency. Their attempt at ranking the scrapers according to the relative results obtained with each of them also is not concordant. The results of this present study which will clarify the matter of efficiencies of scrapers will be discussed later in this paper.

APPARATUS FOR SCRAPER TESTSEquipment used in tests:

The model scrapers available for this present research had been used previously by other students. The scrapers were constructed on a scale of 1 to 6, and are 8 inches wide. The scrapers tested are shown in Figures 1 and 2.

The scrapers were operated with a three-drum hoist with double-faced friction clutches. The drums built of aluminum were mounted on a three-quarter inch line shaft set in ball-bearing pillow blocks.

The hoist was powered by a $\frac{1}{2}$ -horsepower, split-phase, electric

motor using 60 cycle A.C., 115 volt current. The motor furnished 1,750 R.P.M. The drive was belted to a 12-inch pulley on a jack shaft. A three-step cone pulley on the opposite end of the jack shaft was belted to a similar pulley on the hoist shaft. This combination of pulleys gave a theoretical R.P.M. of 155, 211, 233, 317, 429, 475, or 646, as desired, at the hoist.

The checking of the RPM available at the drum was done by S. F. Johnsen. (26) A small thin piece of wood held against a notch in

(26) Johnsen, S.F., op. cit., p. 24

one of clutch plates produced clicks easily counted while the hoist was running. The time interval between a number of clicks was determined by a stop-watch. Several RPM checks were made for each combination of pulleys used in scraper tests. The hoist speed were found to be 160, 242, and 319 R.P.M.

The radii of the hoist drums were 1.48 inches. The hoist cable used was 1/16 inch in diameter. The effective radius of each drum from the center of the drum to the core of the rope thus was 1.51 inches. Therefore, the rope speed was calculated to be 126, 191, 252 feet per minute.

The table upon which the scraper tests were run was 15 feet long and 4 feet wide, and was surfaced with rough "masonite" fiber board. It was possible to lower the end of the table opposite the hoist. An opening one foot square was located two feet from the hoist and was equipped with a three-inch grizzly. Below the grizzly an inclined chute directed the material down to the receiving pan



Figure 1
Box Scraper

placed on the floor. The adjustable end of the table was equipped with two sheave wheels for attaching the cable. Side and back-boards prevented the rock from spilling off the table. The back end had to be lowered to avoid water flowing through the chute.

A Type R Westinghouse recording wattmeter was used to measure the power consumption. It was set up near the hoist as shown on Figure 3. A wiring diagram of the wattmeter and motor is illustrated in Figure 4.

Material Tested:

The rock used was fresh, unaltered granite. The shape of particles was splintery to blocky. Mixed size material was employed, since it is what is most commonly found in mines. It was screened and classified as follows: minus 3/16, plus 3/16 minus 1/2 inch, plus 1/2 minus 1 inch, plus 1 minus 1 1/2 inch plus 1 1/2 minus 2 inches, plus 2 minus 6 inch.

Method of Collecting Data:

A galvanized iron pan of 9 by 53 by 53 centimeters dimension served to receive the rock scraped through the chute. The rock was weighed on an Ohaus balance. The desired moisture content was obtained by adding water as needed, to a known weight of rock on the table. Moisture content was recorded as per cent moisture by weight.

The graphs on the wattmeter chart permitted computation of the amount of power consumed in each test.

Figure 5 shows a portion of one graph, as traced by the wattmeter, and makes obvious the way the amount of power was determined.



Figure 2
Crescent Scraper



Figure 3
Recording Wattmeter
and Hoist

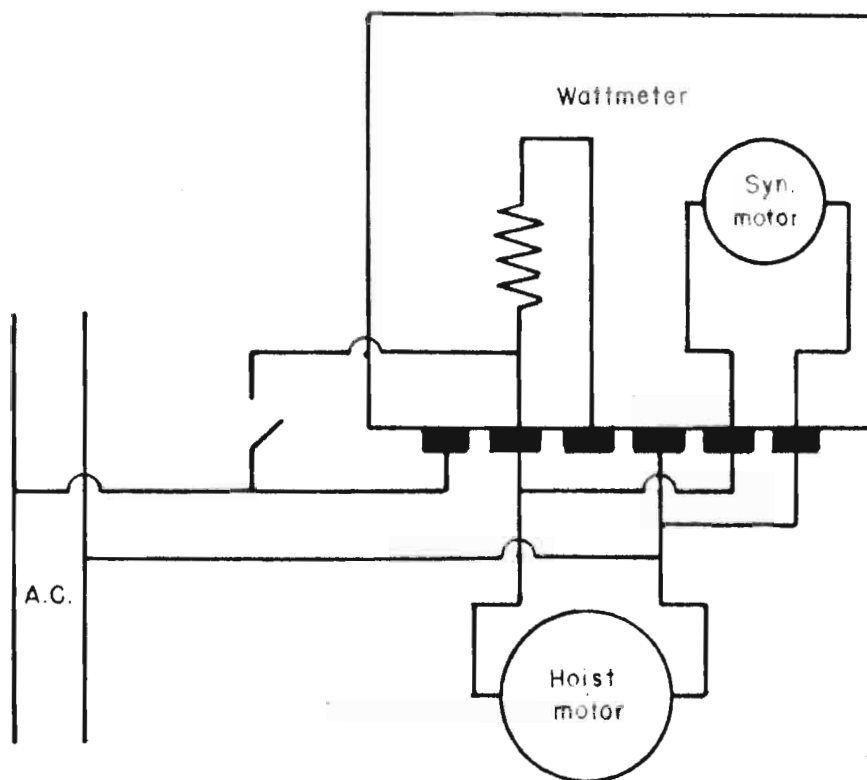

Figure 4
Hoist-Wattmeter Wiring Diagram

Lot No. 112248 S-3 (S) Westinghouse Recording Instrument. C

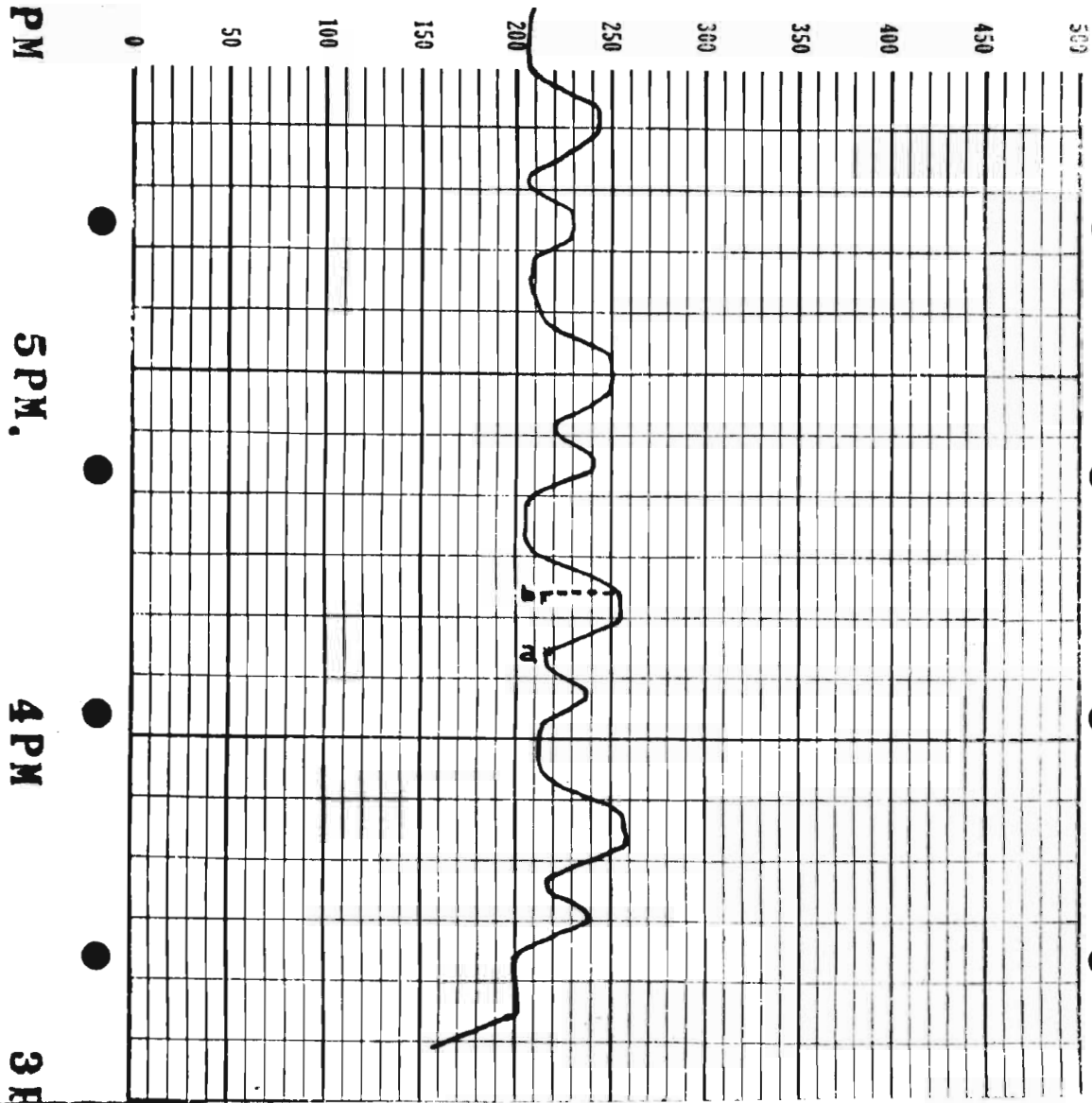

Figure 5
Wattmeter Chart of Model Scraper Test
Box Type, 191 fpm.

For example, the length as divided by 2.84 gives the number of seconds during which the recorded power, p , has been consumed. By multiplying these two figures the number of watt-seconds is determined. By repeating this operation for each cycle on the diagram, and adding the results, the total amount of power consumed during one test is computed.

Application of the principle of similitude:

(27)

As Tolman points out, "the fundamental entities out of which

(27) Tolman, R. C., The Principle of Similitude, Physical Review, Vol. 3, Ser. 2, 1914, p. 244.

the physical universe is constructed are of such a nature that from them a miniature universe, similar in every respect to the present universe, could be constructed." Transformation equations may be established, giving the relation between our physical universe and the experimental miniature universe.

(28)

After Carlson, the necessary and sufficient conditions for

(28) Carlson, R. W., General Structural Similitude, University of California Publications in Engineering, Vol. 3, No. 1, 1933, pp. 139-144.

dynamic and static similitude of a model and a prototype are defined by two rules as follows:

1. The model shall be geometrically similar to its prototype, except as to the dimensions which do not affect the behavior of the model.

2. The force scale-reduction factor shall be the same for

forces arising from each of the various influences.

The following symbols, in which subscripts refer to the model are adopted here for a discussion of such relations as Carlson has proposed.

w and w_1 are densities of material.

L and L_1 are linear dimensions. The scale-reduction factor of length, L/L_1 is termed n .

F and F_1 are homologous forces.

v and v_1 are velocities of corresponding points.

t and t_1 are time intervals, so defined that for periodic motion each represents the same phase change.

a and a_1 are corresponding accelerations.

The gravitational-force ratio is given by:

$$\frac{F}{F_1} = \frac{wL^3}{w_1L_1^3}$$

Inertial force is the product of mass and acceleration. Consequently it varies as the density, volume, and acceleration of the considered system. Since acceleration varies as the velocity, and inversely as the time, the inertia-force ratio is equal to:

$$\frac{F}{F_1} = \frac{wL^3 vt_1}{w_1L_1^3 v_1 t}$$

Application of Carlson's Rule 2 (above) results in the following equation:

$$\frac{F}{F_1} = \frac{wL^3}{w_1L_1^3} = \frac{wL^3 vt_1}{w_1L_1^3 v_1 t}$$

Maintenance of geometrical similarities under all phases of motion and degrees of load, requires that the length units which go with t and t_1 to make v and v_1 , must be proportional to L and L_1 . Thus, replacing v and v_1 by their equivalent values, L/t and L_1/t_1 , gives:

$$\frac{F}{F_1} = \frac{wL^4 t_1^2}{w_1 L_1^4 t^2} = \frac{wL^3}{w_1 L_1^3}$$

Hence, two equations are established, as against four scale-reduction factors; F/F_1 , w/w_1 , L/L_1 , and t/t_1 and the free choice of two of the scale-reduction factors is permitted.

The model scrapers used in this experimentation have been constructed in such dimensions that the reduction factor (L/L_1) of length is fixed at $L_1 = 1/6$ of its prototype, commercial, full-scale scraper. Therefore, the choice in the tests rested among one of the factors F/F_1 , w/w_1 , or t/t_1 . Nevertheless, the factor, to be selected from among these three possibilities, has to be chosen carefully in order that the applications of the relations deduced from its choice do not give rise to absurd results. For instance, it may be assumed that the densities of the material to be scraped either in industrial practice or in model testing is the same. Then:

$$L/L_1 = n = 6$$

$$w/w_1 = 1$$

$$F/F_1 = n^3 = 216$$

$$v/v_1 = n^{\frac{1}{2}} = 2.45$$

$$t/t_1 = n^{\frac{1}{2}} = 2.45$$

If p be taken as the power consumption and P the rated horsepower

of the hoist motor, then

$$P/P_1 = n^4 = 1,296$$

$$P/P_1 = n^{7/2} = 530$$

This establishes that a motor of about 130 H.P. will be required to activate a three-drum hoist in industrial practice. A sensible choice of the factors which are left to our determination will allow, and make valuable, further interpretation of the conclusions arrived at by studies of the model equipment.

It also becomes evident that so much depends, in underground practice, on non-measurable elements, that a mere generalization of model test results cannot be wholly satisfactory.

However, the data obtained by model experimentation may furnish indications of the variations which might be expected to accrue when the corresponding elements of the prototype are varied in a similar way.

DESCRIPTION OF MODEL SCRAPER TESTS

As said previously, crushed granite was used for the tests. The granite was mixed in proportions, as follows: Minus 3/16 inch, 55%; plus 3/16 minus 1/2 inch, 25%; plus 1/2 minus 1 inch, 10%; plus 1 minus 1 1/2 inch, 5%; plus 1.5 minus 2 inch, 3%; plus 2 minus 6 inch, 2%

The granite was placed at one end of the table. Twenty passes from the muck pile to the grizzly were run for each test. The material then was weighed. The power consumed was recorded on a graph during the operation, and the total amount of power was computed.

The muck pile always was set in the same position and was given the same shape before each test. Part of the load was lost during the first passes. However, ridges quickly were built up, which avoided further losses of consequence.

Not only the importance of the shape of the pile, but the importance of the repartition of the chunks inside it, were recognized during the operations. In the course of the scraping a kind of natural segregation transpired, and, if too many big lumps appeared in the surface, the digging ability of the bucket was impaired and important variations in the results would develop if attention was not paid to these two factors. It is the belief of the writer that 20 passes per test represent a minimum, and that possibly as much as 100 would give an average result tending to elimination of the above sources of error. However, lack of time did not allow the successive operators to run more than 20 passes per test. As the aim of these studies is not to give absolute figures, but to bring out relative variations, the procedure adopted is deemed to be sufficiently accurate.

The use of the three-drum hoist permitted scraping from any locality on the table. To avoid additional power consumption, and to operate the tests in about the same conditions, the maneuvering was reduced as much as possible.

One hundred and twenty tests were run. The rope speeds used were 126, 191 and 252 fpm. For speeds over 252 fpm the box and crescent scrapers bounced too much to yield reliable data. Each of the scrapers was tested for four different weights and zero, five, ten, fif-

teen and twenty per cent moisture values were successively tried. Each time the true moisture content of the material was determined by taking several samples and weighing before and after drying. The results were as follows:

Moisture added (% in weight) : 0 : 5 : 10 : 15 : 20 :

Moisture content (% in weight) : 0 : 4.8 : 6.9 : 7.1 : 7.2 :

The water which was not absorbed by the rock remained spread on the table.

After completion of all the tests, an examination of the results showed that eleven of them seemed to present elements of singularity. They were rerun for checking purposes. The new figures obtained were more satisfactory and therefore were recorded as true values.

The results obtained were plotted in two types of curves: (1) The first type of curve is established by plotting "watt-second per gram scraped" in ordinate and "per cent of moisture" in abscissa. These curves give for each weight and rope speed the variation of power consumed in function of moisture added. (2) The second type of curves are obtained by plotting "gram scraped per gram of scraper" in ordinate and per cent of moisture in abscissa. These curves give for each weight and rope speed the variation of efficiency of each scraper bucket. The second type of curve gives a fair representation of the variation of efficiency of a scraper when operated under given conditions of weight and rope speed. In practical usage, one of the chief concerns of the operator is the quantity of muck pulled. Unfortunately, the curves do not indicate such a relationship.

For example, a scraper weighing 2060 grams, and having an effic-

iciency of 1.65 grams of rock per gram of scraper, carries 3,400 grams per pass. The same type of scraper weighing 1140 grams and having an efficiency of 1.96, carries a load of only 2,220 grams. Consequently, the coefficient "grams of rock per gram scraped" does not allow a direct comparison of results obtained where different weights are used. As the amount of load carried is an important point to know when judging the overall efficiency of a scraper, these figures are compiled in the tables placed in appendix. (See appendices A to F).

(29)
Johnsen states that the addition of moisture to the muck

(29) Johnsen, op. cit., p. 51.

does not increase the efficiency of scrapers. This result was corroborated in a more specific way. That is, it has not been found possible, in the present research, to give the scrapers such a definite rank on the basis of their efficiency ratings during the moisture tests. Hence, this experimentation has shown that the first rank in efficiency shifts from one to the other types of scrapers when the values given to the different variables are changed.

Box Type Scraper Tests:

Graphs 1, 2, and 3 show that power consumption increases with an increase in moisture content. As it is the weight of dry rock scraped which has been figured, and considering the fact that the denser muck pile is more difficult to dig, the shape of the curves look logical.

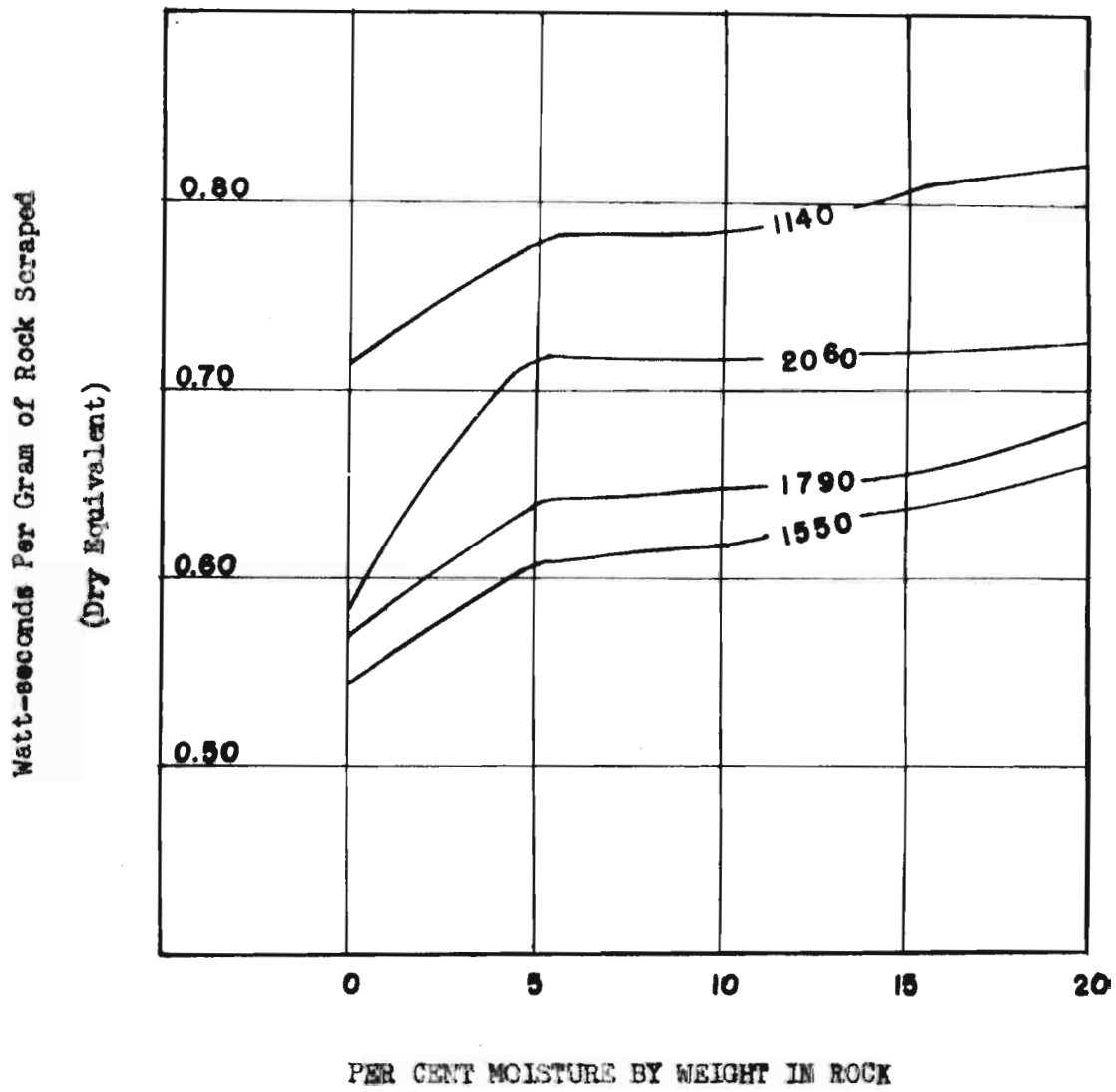

Graph 1. Relationship between moisture content of rock and power consumption.

Box Type
126 fpm

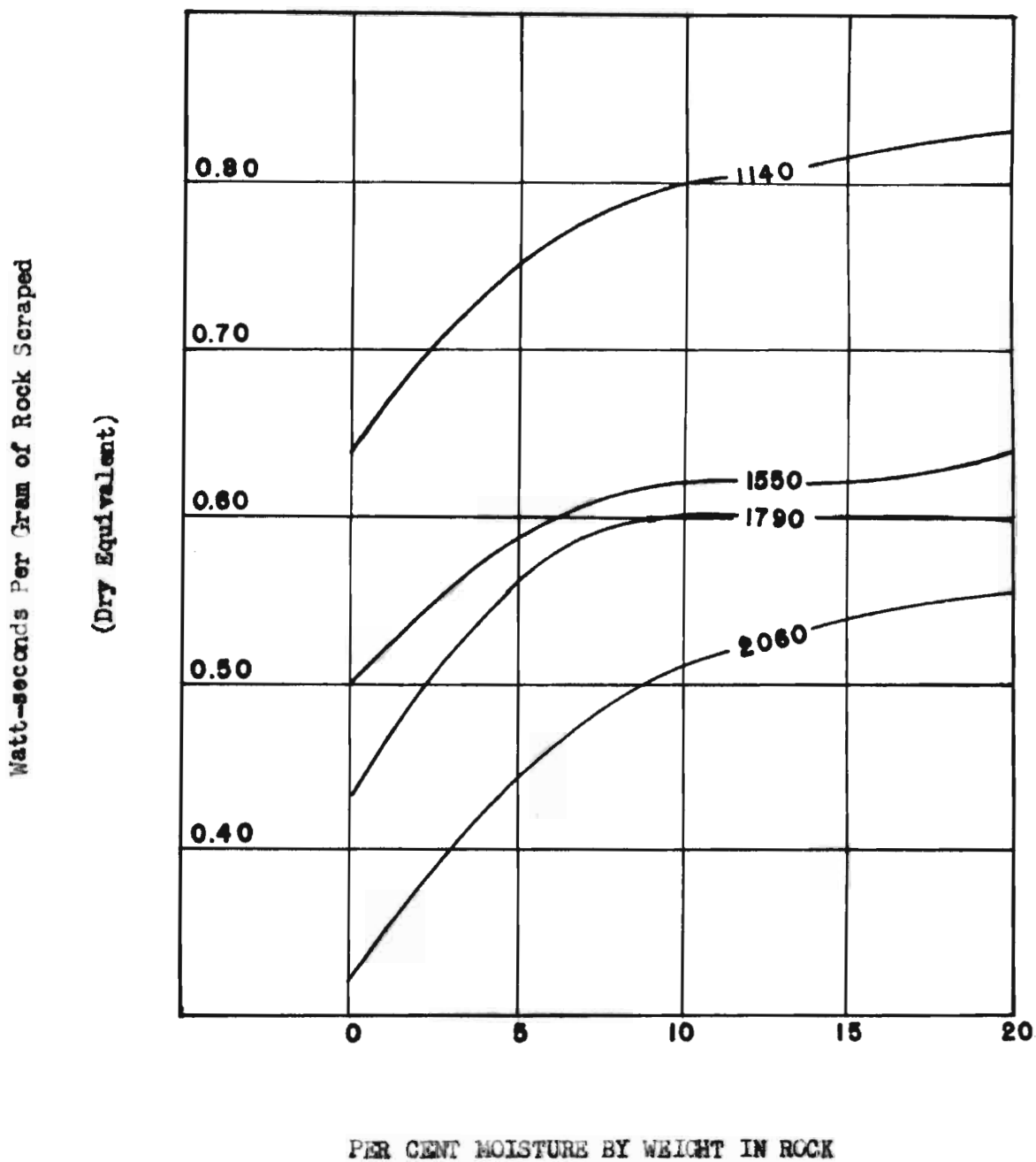

Graph 2. Relationship between moisture content and power consumption.

Box Type
191 fpm

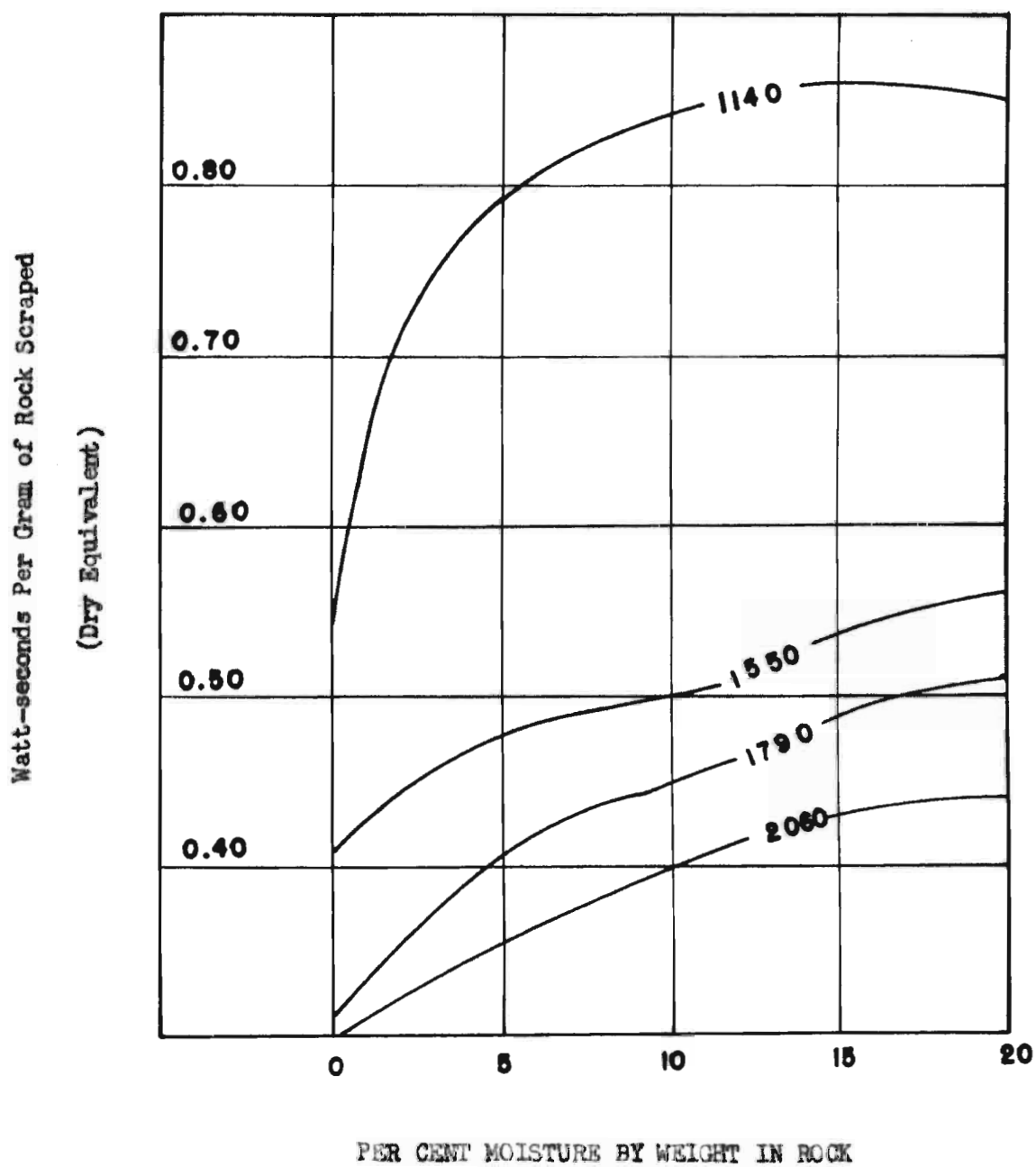

Graph 3. Relationship between moisture content and power consumption.

Box Type
252 fpm

The maximum rate of increase is obtained when moisture content rises from 0 to 5%. As has been stated before, beyond 5%, the true moisture of the rock shows very little augmentation with greater addition of water. It explains why the curves show a tendency to flatten.

The graphs also show that at a given speed power consumption is the lowest for a given weight. They establish, too, that the optimum efficiency is obtained for heavier weights as speed increases, and that the difference in power consumption between light weights (1140 gms) and heavy weights (2060 gms) becomes more important as speed is increased.

Graphs 4, 5, and 6 prove that the load which can be carried decreases as moisture content grows higher. The drop in efficiency is more pronounced with the lighter scrapers than with the heavier ones. The graphs and tables in the appendices also indicate that the quantity of material scraped at a definite speed is at a maximum at a given weight and that the most favorable results are obtained with heavy scrapers.

The important fact to be noted is that the relative disposition of the points of intersection of the curves drawn for a given speed, with parallels to the ordinate axis, do not vary whatever the moisture content may be. Consequently, at any moisture content, the variations in efficiency will be represented by curves exactly parallel to those determined in previous studies of scraping dry rock when the same variables are considered. Conclusions drawn from studies of the dry tests on scraper models are available for any moisture content.

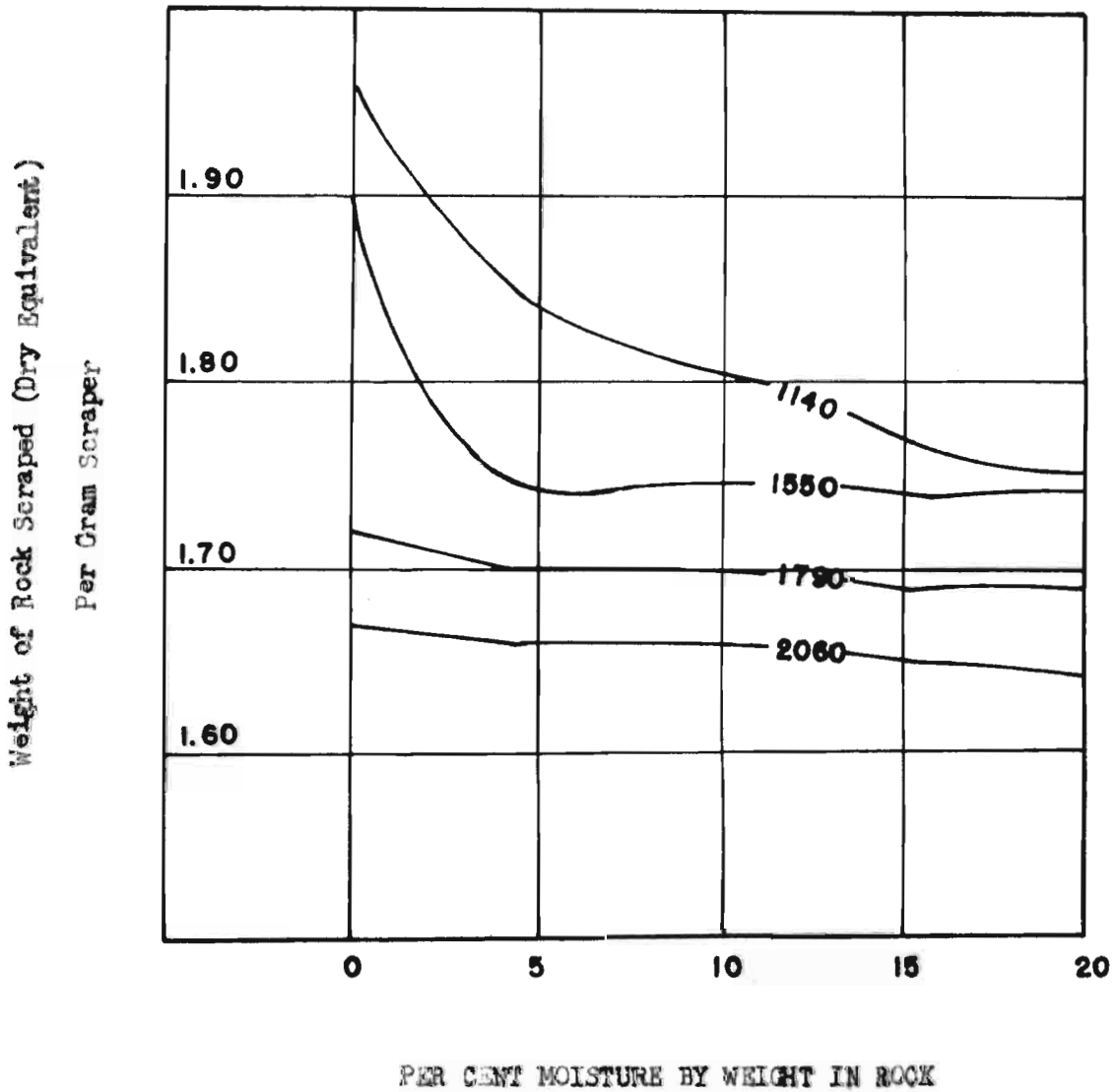

Graph 4. Relationship between moisture content and weight of rock scraped.

Box Type
126 fpm

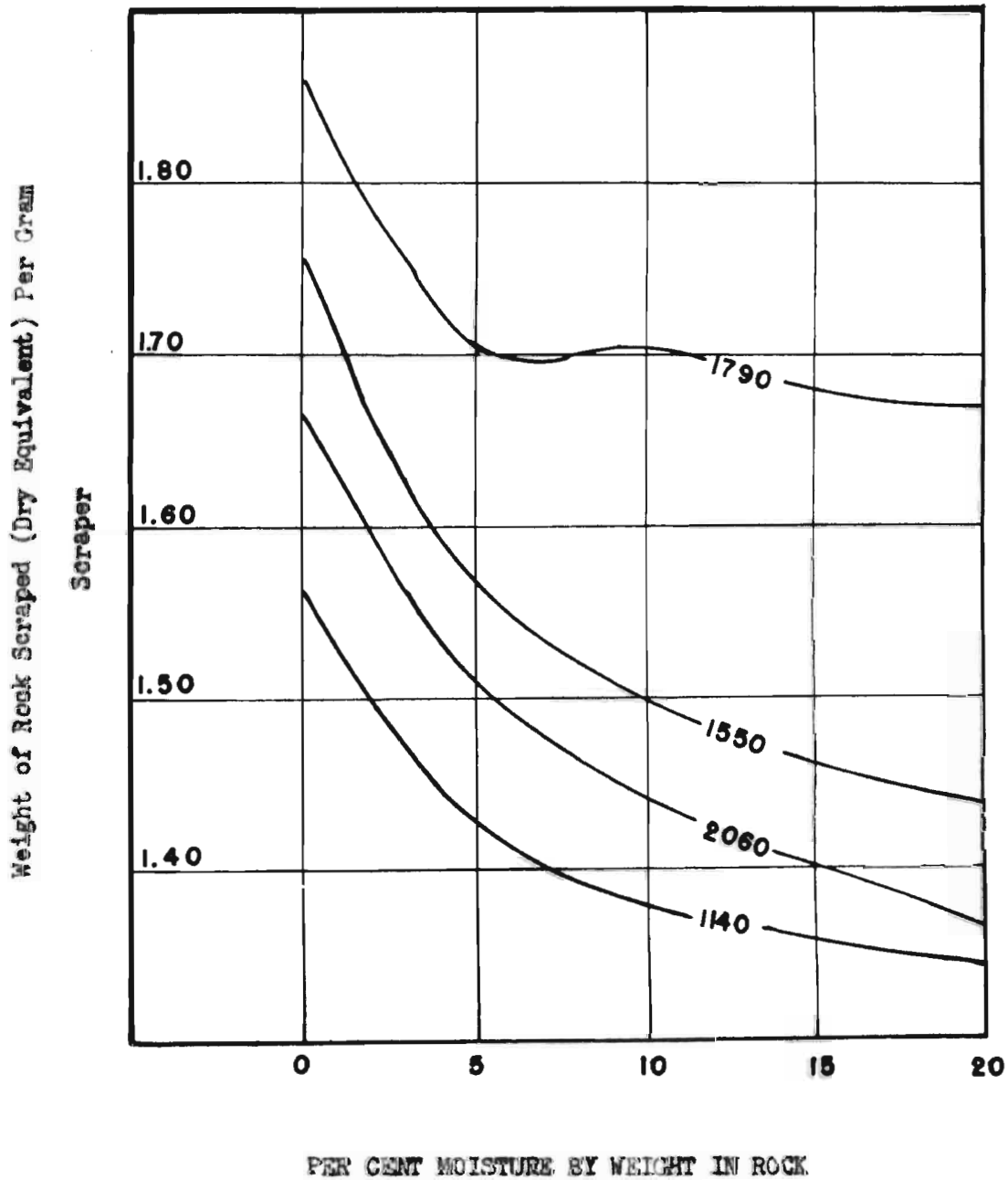

Graph 5. Relationship between moisture content and weight of rock scraped.

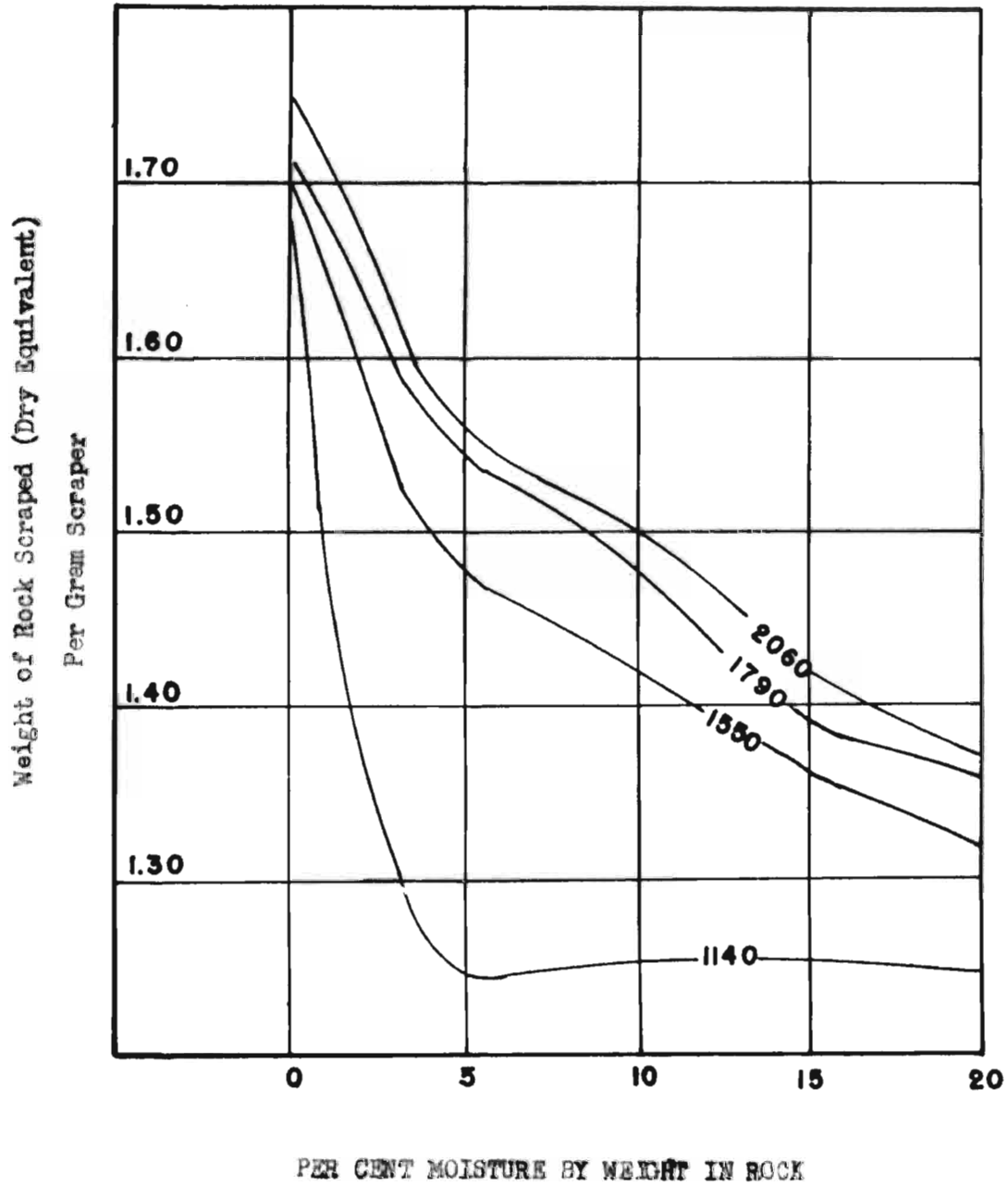

Graph 6. Relationship between moisture content and weight of rock scraped.

Box Type
252 ipm

Crescent Type Scraper Tests:

The crescent scraper is affected by a variation in moisture in much the same manner as the box scraper. However, ranges of variation were more important than for the box type.

The curves in graphs 7, 8, and 9 demonstrate that an increase in moisture content increases power consumption, and that, as the disposition of the curves prove, conclusions reached for dry rock studies are still expressed in the same manner as if water were used. They show that at a definite speed, power consumption is at a minimum for a given weight and that this weight, for which there is a minimum power consumption, tends to become greater as speed increases. Also, the power consumed reaches a new minimum as the speed increases.

Graphs 10, 11, and 12 establish that the efficiency of the crescent scraper, expressed as grams of rock scraped per gram weight of scraper, drops with the addition of water. Tables in the appendices indicate that the quantity of material carried per pass is at a maximum at a definite speed for a definite weight.

How Tests May Help to Chose the Best Operating Conditions:

The preceding comments have stressed the importance of a proper selection of the rope speed and of the type and weight of scraper when scraping operations are contemplated.

The miner is interested in scraping a big amount of material at low cost. Consequently, the efficiency of the scraper as regards weight of muck carried, and power consumption, are two items which

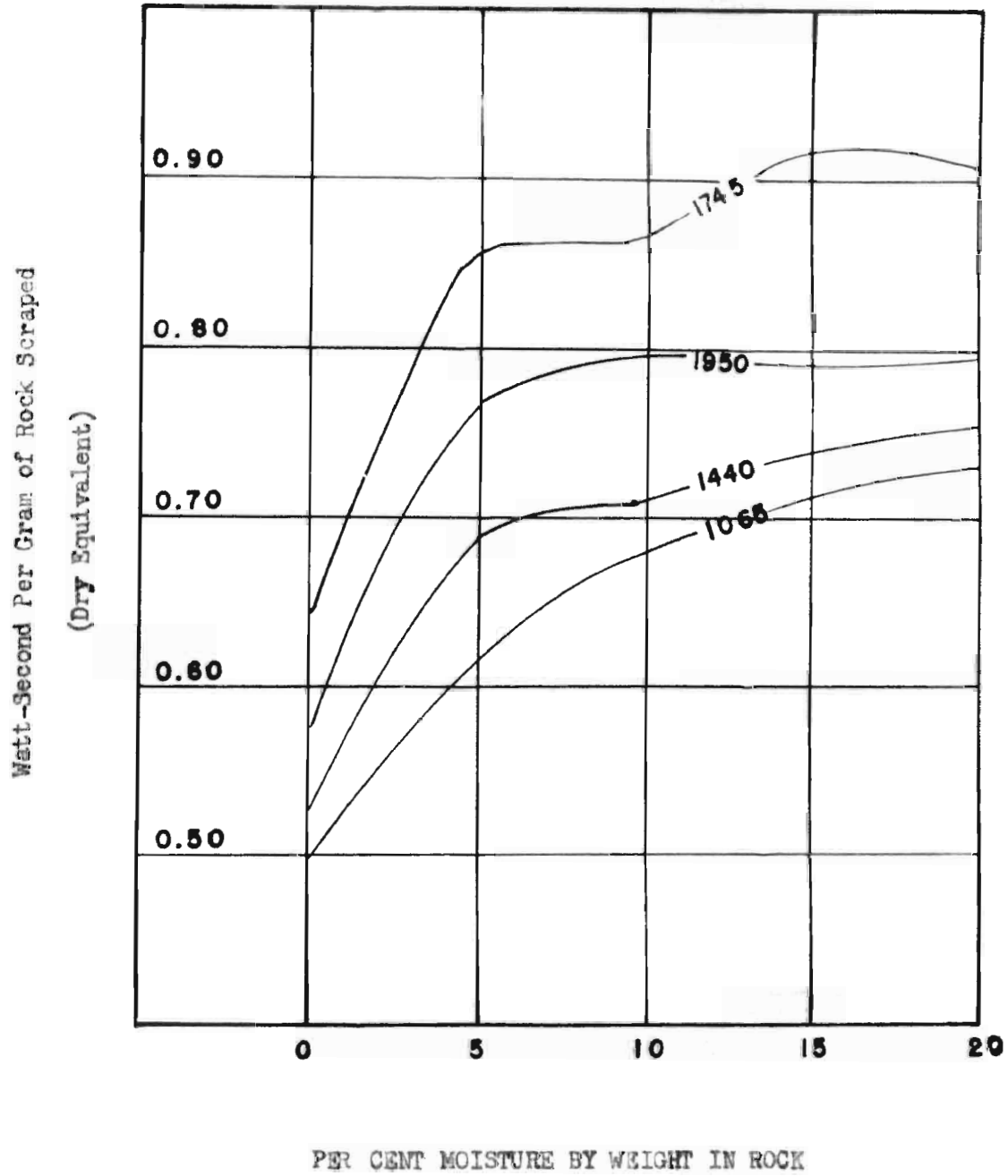

Graph 7. Relationship between moisture content of rock and power consumption.

Crescent Type
126 fpm

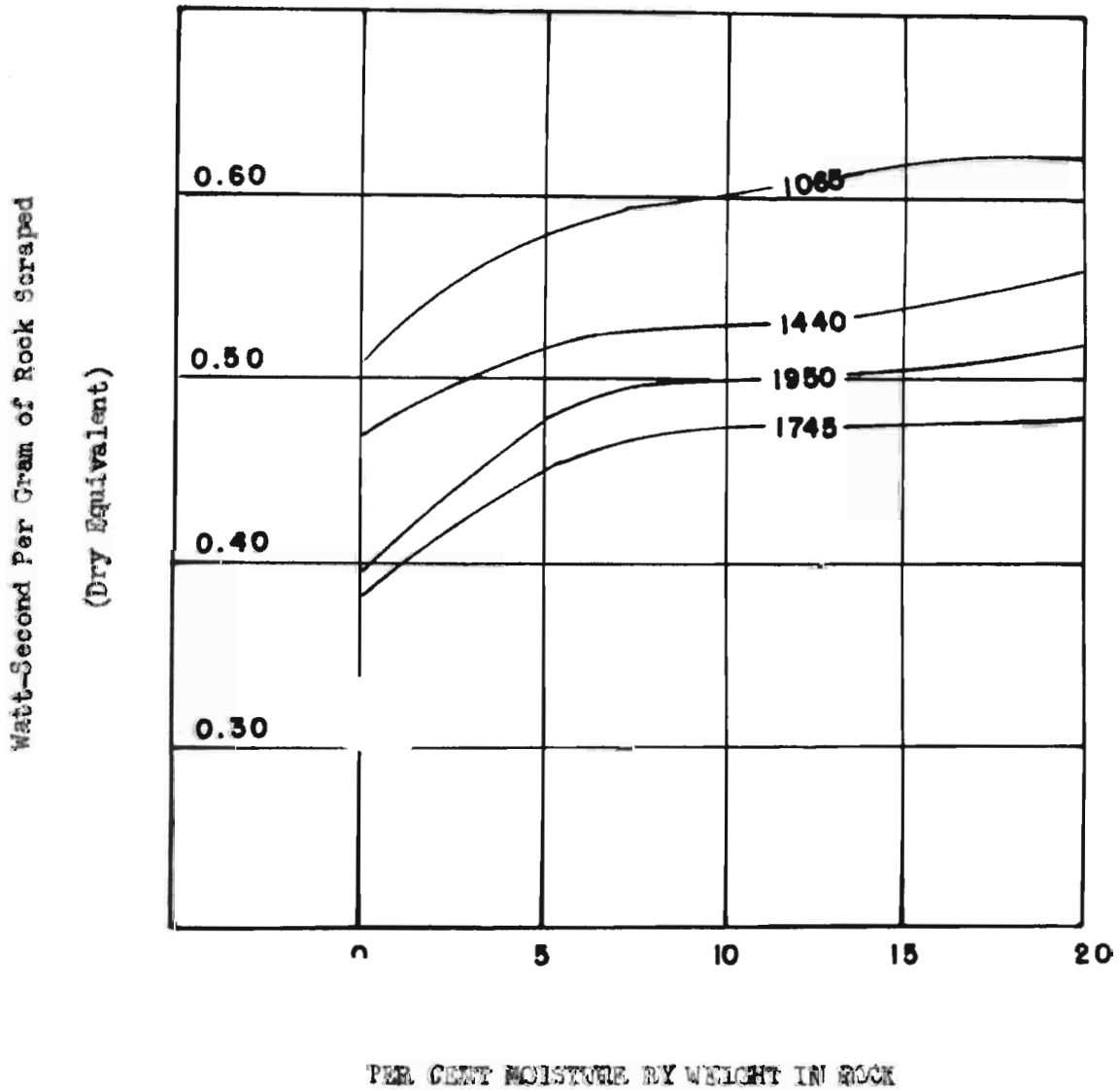

Graph 8. Relationship between moisture content of rock and power consumption.

Crescent Type
191 fpm

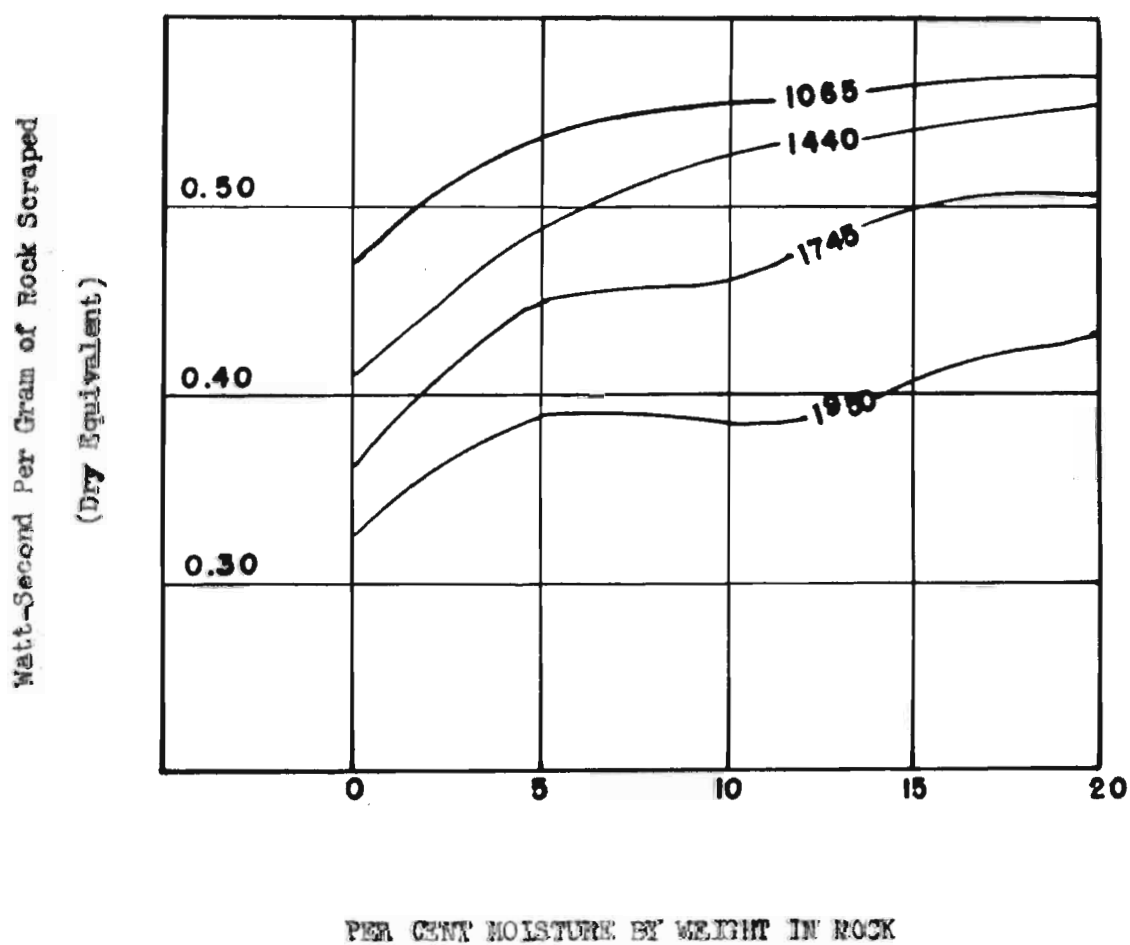

Graph 9. Relationship between moisture content and power consumption.

Crescent Type
252 fpm.

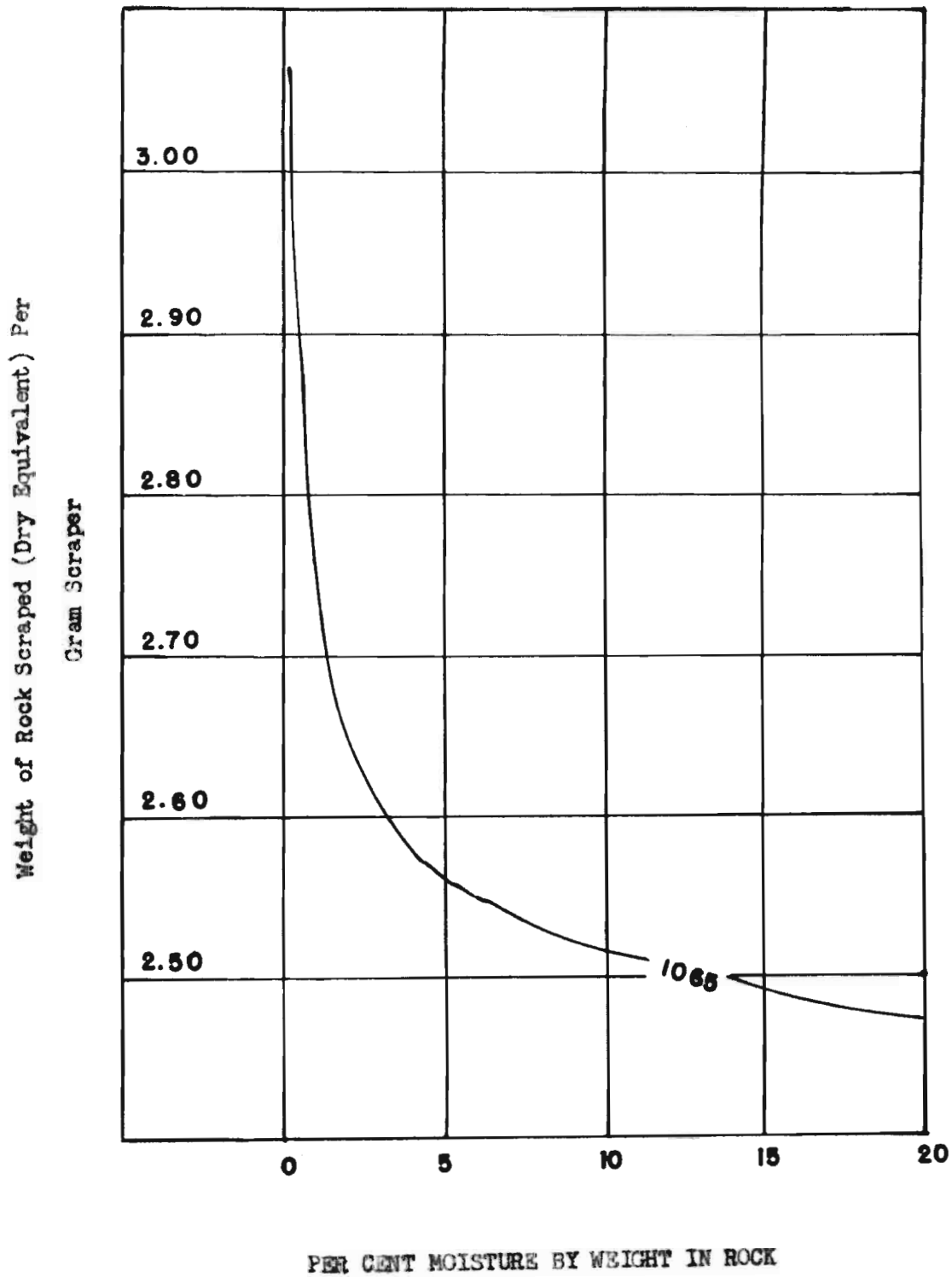

Graph 10. Relationship between moisture content and weight of rock scraped.

Crescent Type
126 fpm

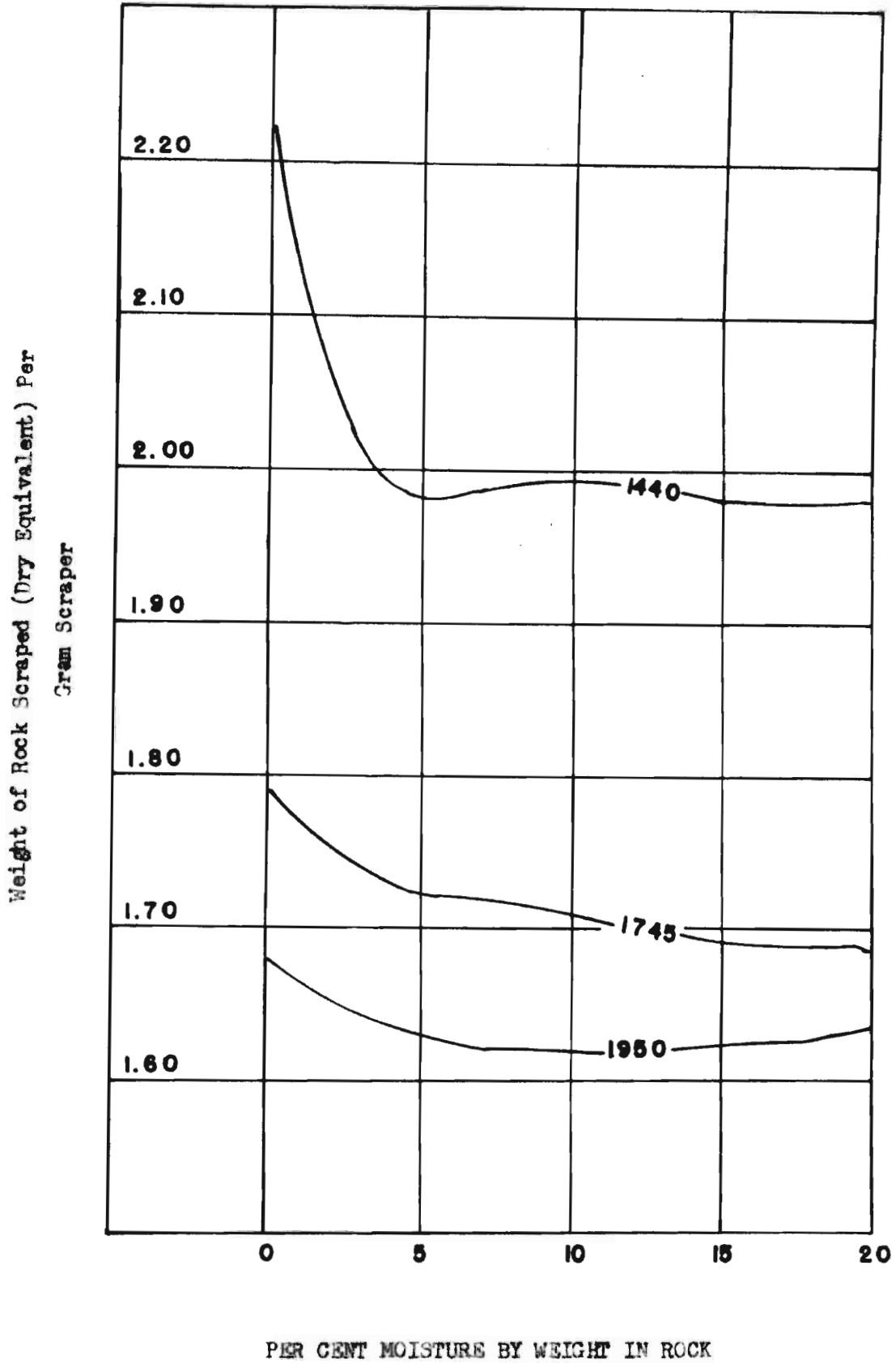

Graph 10. continued.

Crescent Type
120 fpm

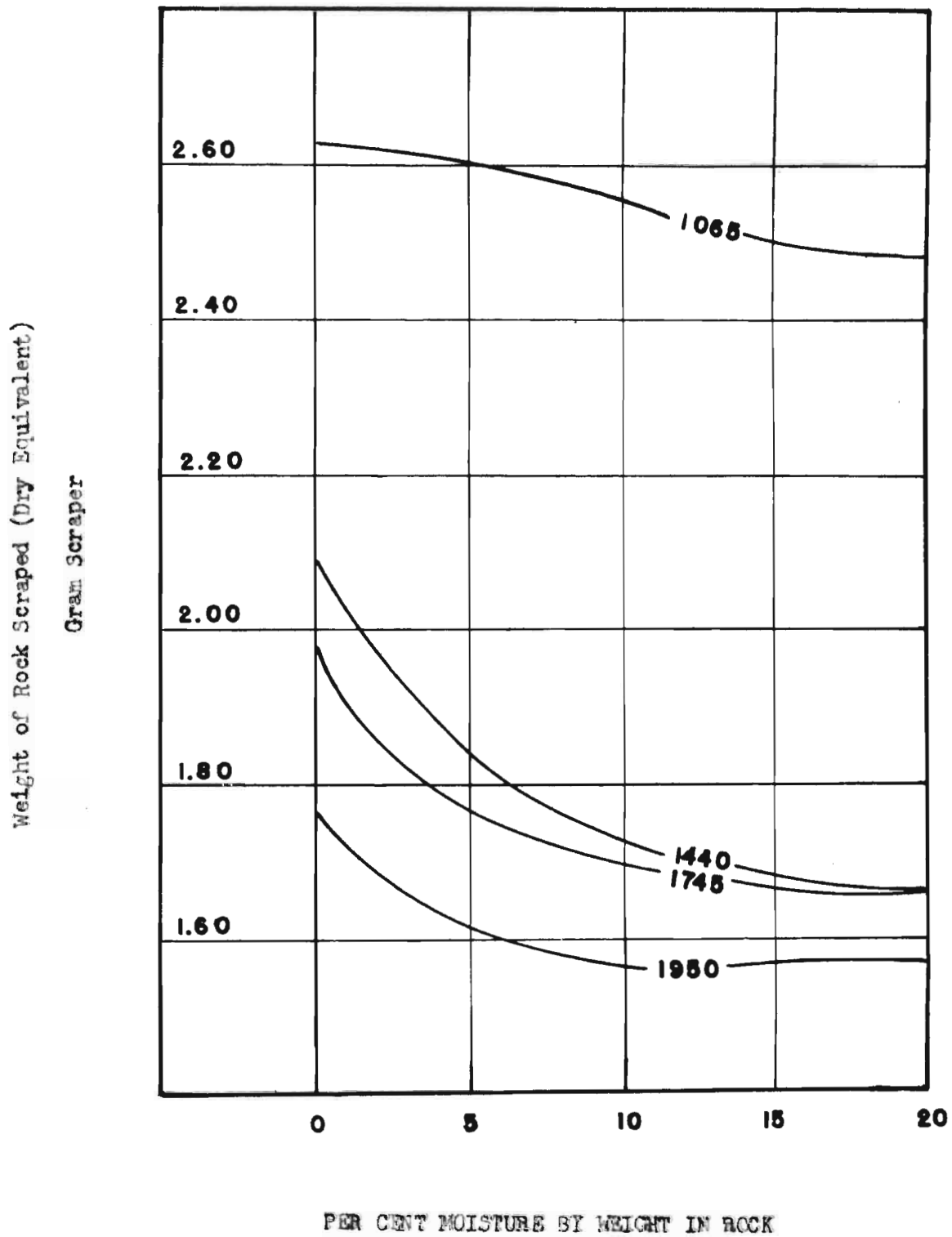

Graph 11. Relationship between moisture content and weight of rock scraped.

Crescent Type
191 fpm

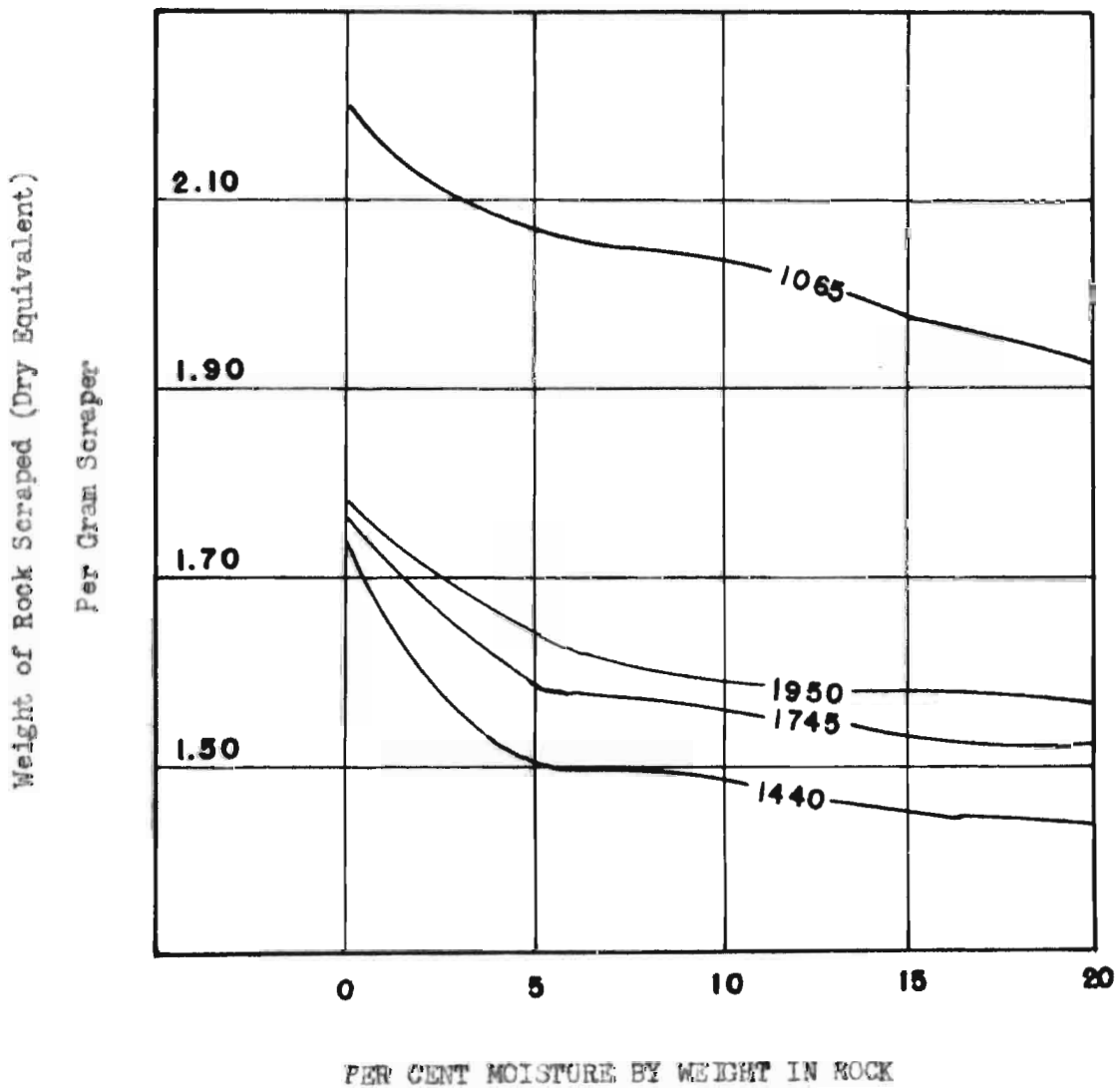

Graph 12. Relationship between moisture content and weight of rock scraped.

Crescent Type
252 fpm

should guide his choice.

Time studies may show which speed will be the better. It is more difficult to determine when power consumption will be the lowest and what will be its direct effect on the cost.

Tests similar to those that have been carried out may give values whereby the average load and power consumption per pass for different weights of scrapers may be determined. A greater amount of rock scraped may be accompanied by such an increase in power consumption that the cost may be higher than what would be the case with another weight of scraper giving a lesser load capacity per pass.

The question is raised as to how the best operating conditions may be determined; that is, the most favorable set of values for weight of scraper and power consumption? Even though the solution may appear obvious in some cases a theoretical solution may be developed to obtain easily an answer for any case. For example,

Let i be the investment and maintenance cost per unit of weight of material, and;

L = labor cost

E = energy cost

m = average load per pass at a given weight of scraper

p = power consumption per pass

l = average length of haul

v = speed

t = time to run a pass

h = unit rate of wages

r = cost of unit of power

c = total cost per unit of weight of material

Then, the total cost per pass will be,

$$cm = im + L + E$$

$$L = ht = \frac{hl}{v}$$

$$E = pr$$

$$cm = im + rp + \frac{hl}{v}$$

If l and v are fixed, the equation becomes,

$$(1) \quad cm = im + rp + L$$

Now, given two sets of conditions, (m_1p_1) and (m_2p_2) , it is desired to ascertain which will make c the lowest. If corresponding values for m , p , and c are plotted on three rectangular axis of coordinates, relation (1) represents the equation of an hyperbolic paraboloid. As it is a ruled surface, the determination of its generators will help to obtain graphically the desired solution.

Intersection of the surface (1) with the plane

$$im + rp + L = 0$$

is composed of the two lines:

$$c = 0$$

and

$$\begin{aligned} im + rp + L &= 0 \\ m &= 0 \end{aligned}$$

represented on Figure 6 by AB and AX.

Intersection of the surface with the plane

$$im + rp + L = c$$

is the line

$$\begin{aligned} im + rp + L &= c \\ m &= 1 \end{aligned}$$

represented by ED on Figure 6.

It is apparent that the hyperbolic paraboloid is generated by horizontal lines, such as AB, parallel to the plane $c = 0$, and passing through the lines ED and AX.

It is more convenient to represent the surface by a descriptive geometry process, (Figure 7):

ax is the projection of AX
 ed and e_1d_1 the projections of ED
 ab and a_1b_1 the projections of AB

For each set of values for m, and p, a new point N is established on the surface and is projected in n (Figures 6 and 7).

The c-coordinate of the point of intersection with the surface of the vertical line passing through N has to be determined. The intersection of the plane MAX with the paraboloid is composed of the line AX and an horizontal line easy to construct: Figure 7 shows the process. The vertical plane max cuts the vertical plane ed following the vertical line p_1q_1 , q. The horizontal line p_1n_1 passing through p_1 is the line sought. n, n_1 is the point on the paraboloid of which the projection on the plane pom is n. Hence the procedure for comparing costs is as follows:

Two sets of values, (m,p), (m_1,p_1) are plotted as points n and r. Lines an and ar cut line cd in q and s. Then p_1q_1 and u_1s_1 represent the corresponding costs. The process is simple and allows a ready comparison of the unit costs. Also, it is evident that the costs will be the same when n and r are in a straight line with a.

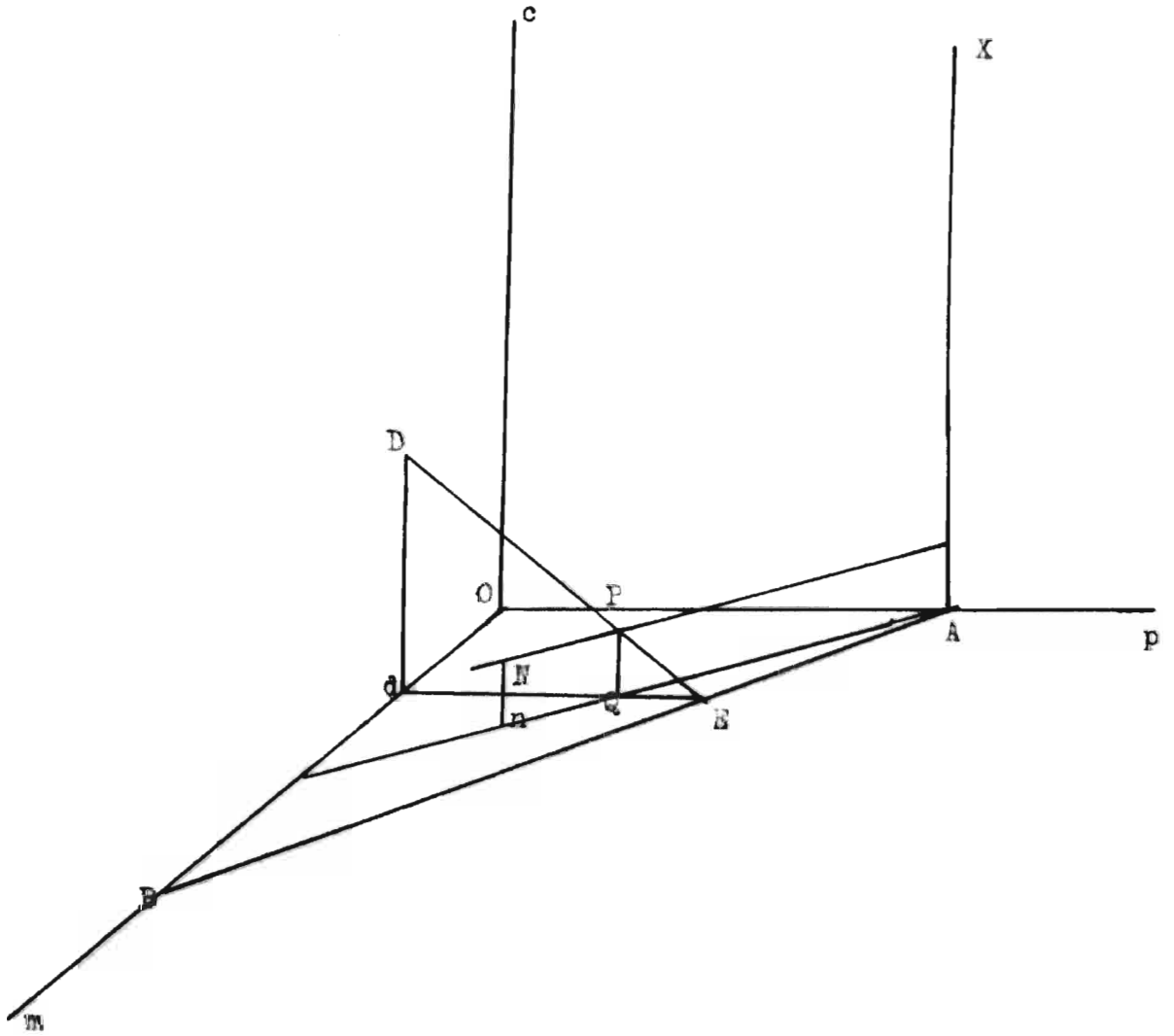

FIGURE 6.

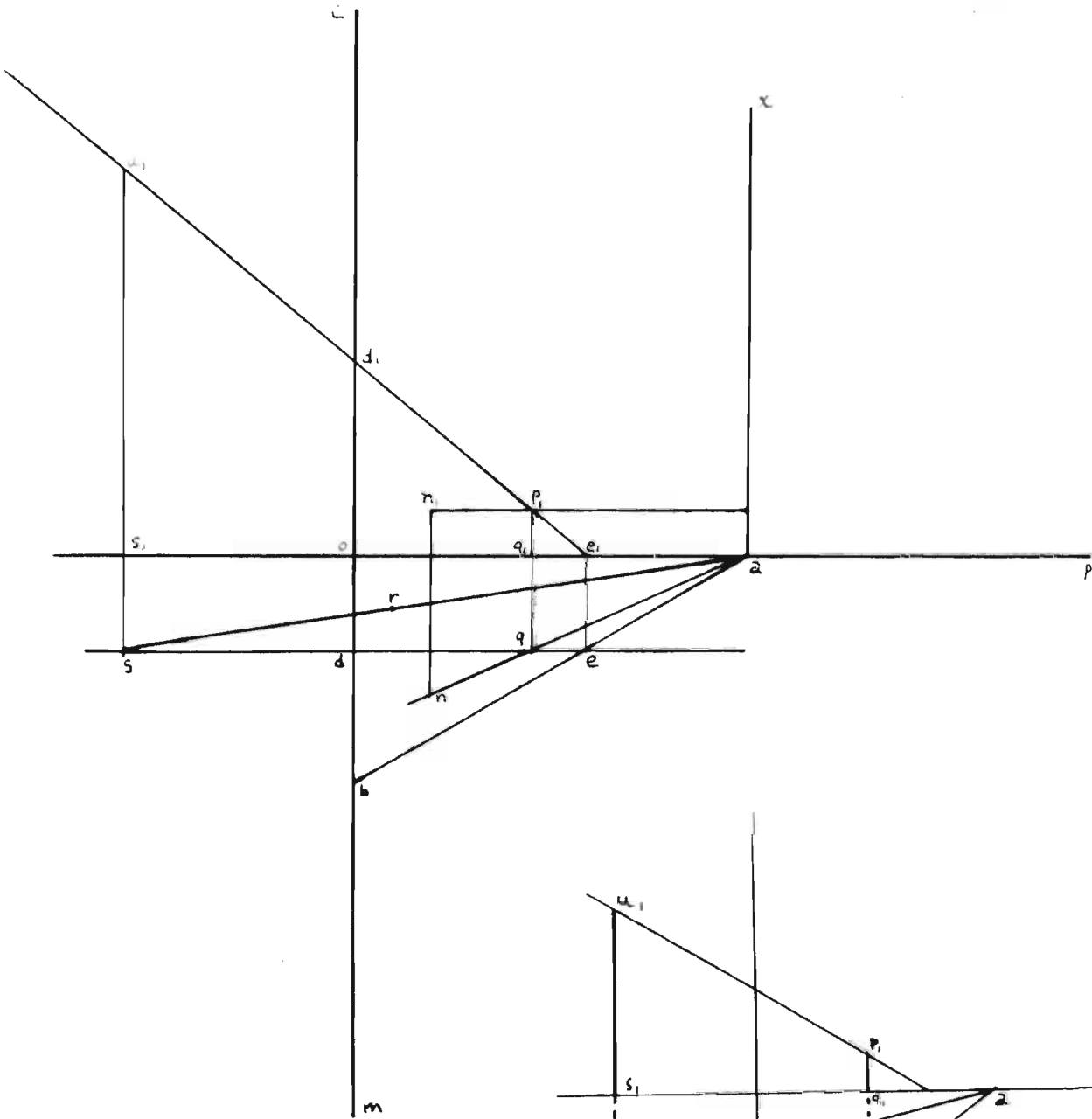

Figure 7

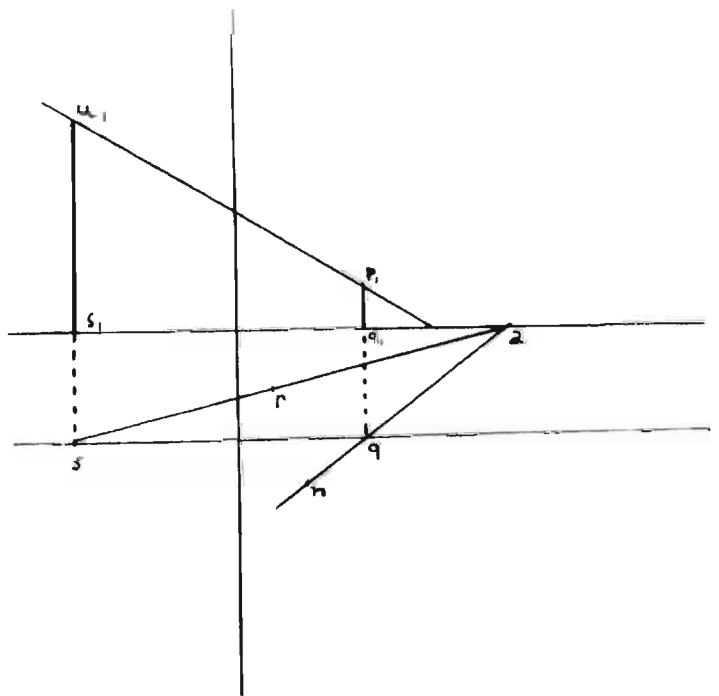

Figure 7a

arn is then the projection of a horizontal generator of the paraboloid.

In generalizing the solution, two types of scraper equipment for which i , and v would be different may need to be compared. The relations between our variables would be:

$$(1) \quad cm = im + rp + L$$

$$(2) \quad cm = i_1 m + rp + L_1$$

The descriptive representation of the two paraboloids is given on Figure 8. The first one is defined by the generators (a and ax), (ed, and $e_1 d_1$) (ab, and ao). The second one is defined by the generators (j, and jy), (gd, and $g_1 h_1$), (jf, and jo).

The procedure to be followed in making a solution is the same as above given. Let the costs be compared for a given set of values (m, p), which is represented by point n in Figure 8. Line an cuts cd in q, jn cuts it in s. Then $q_1 r_1$ and $s_1 u_1$ (see Figure 8) are the two costs that have to be compared.

The curve intersection of the surfaces (1) and (2) is located in the plan:

$$(3) \quad (i - i_1) m + L - L_1 = 0$$

It is a hyperbola projected in the plan pm following the line defined by equation (3). All the points located on that line are such that they will define sets of conditions producing the same costs in the two systems considered. By a generalization of what is called, in engineering economy studies, the "break-even point" it can be called a "break-even line". It divides the plane into regions for which one of the set-ups is the most favorable.

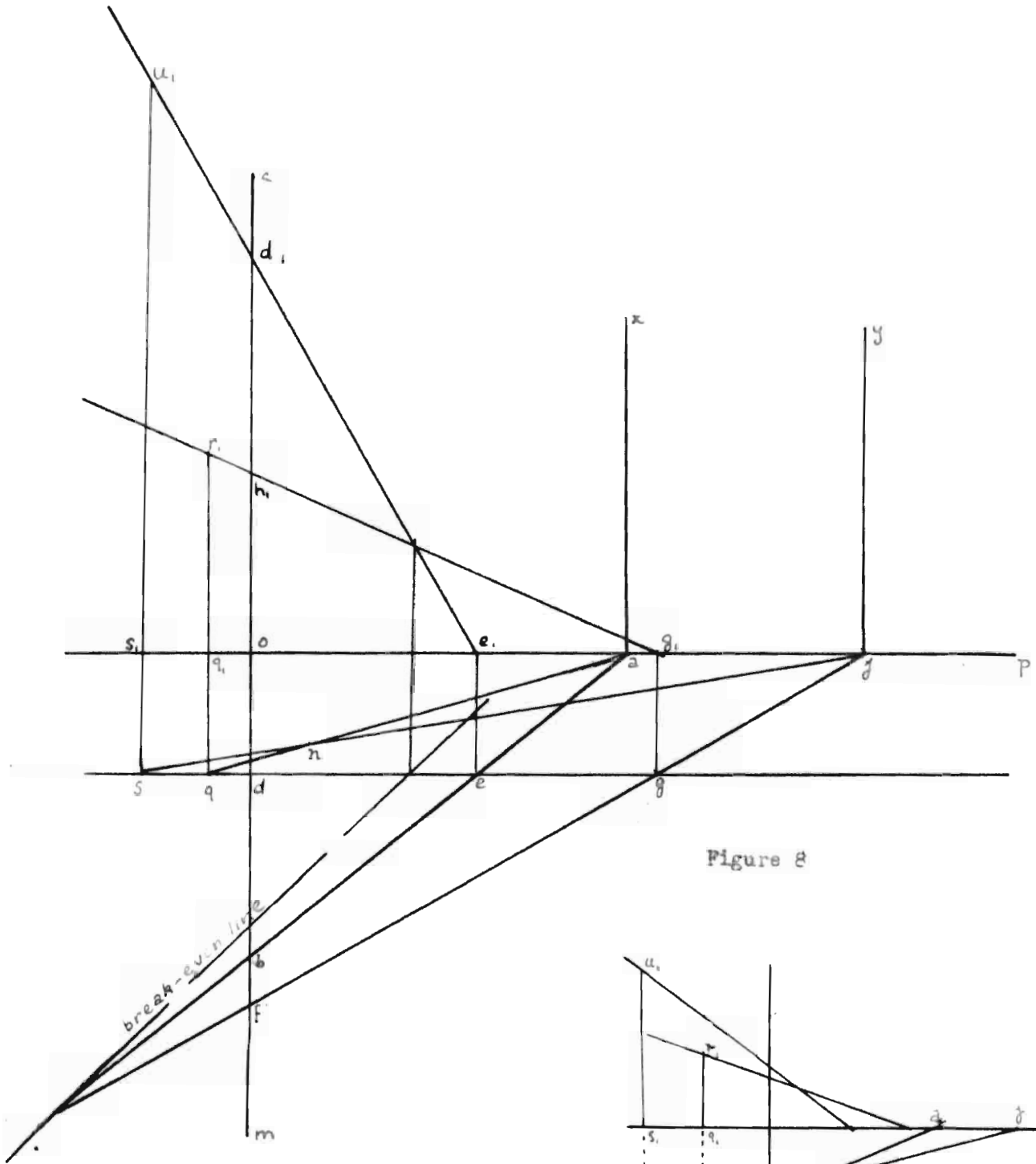

Figure 8

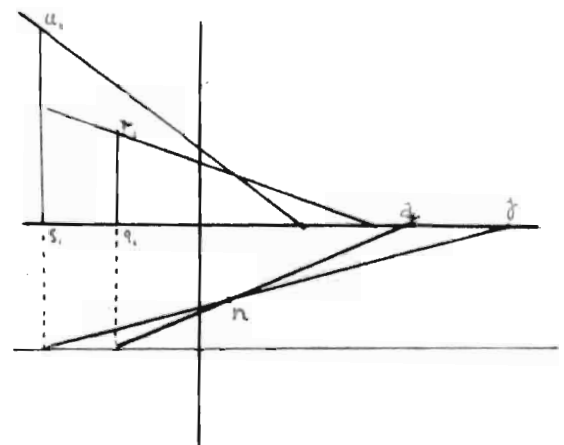

Figure 8a

Illustrates how easy is the determination of costs on a graph paper.

CONCLUSIONS DRAWN FROM STUDY OF MODEL SCRAPERS

1. The addition of moisture decreases the efficiency of scrapers.
2. When the same set of variables are considered, similar results are obtained with the wet rocks as were obtained, in previous studies, with dry rocks.
3. At a given speed, power consumption is at a minimum for a given weight, and, at the same time, the power consumed reaches a new minimum as the speed increases.
4. The optimum weight grows heavier with increases in rope speed.
5. At a given speed, the amount of rock scraped has an optimum for a given weight.
6. Heavy weights of scraper favor heavy load per pass.
7. Minimum power consumption and maximum load moved are not necessarily realized simultaneously. Time studies, and engineering economy studies are both necessary to establish the best operating conditions.

SUMMARY OF SCRAPER TESTS

Two model scrapers were tested to determine the effect of moisture on their efficiency, and to ascertain the best conditions under which the respective scrapers could be operated. Variations in power consumption and amount of rock scraped were recorded when weight of scraper, rope speed, and moisture content of the muck were varied.

The models tested were the box and the crescent scrapers. They were constructed on a scale of 1 to 6 and were 8 inches wide. The rock used was crushed granite of mixed size.

One hundred and twenty tests were run. Added moisture ranged from 0 to 20 per cent of the weight of the muck and the rope speeds ranged from 126 to 252 feet a minute in different tests.

It was found that moisture decreases scraper efficiency and increases power consumption. These findings are similar to those found by previous experimentation conducted on dry muck. In any case, when a particular rope speed of hoisting is employed, there is a given weight of scraper which should be used to realize optimum conditions of scraper efficiency and power consumption.

Power consumption and carrying efficiency are not at the best at the same time. Only conjugated time studies and engineering economy studies can help determine the most favorable operating conditions.

It is the opinion of the writer that the aim of model scraper studies is not to give results directly exploitable in practice by the direct application of similitude ratios. The greatest value of

such studies lies in the fact that by model experimentation it is possible to establish relations of variables that will indicate probable optimum operating conditions that should exist in the commercial prototype.

Further studies with a material of different density would be useful in order to ascertain if the conclusions drawn from this present work may be generalized to obtain for any kind of material.

APPENDIX A

Rope Speed Tests at 126 FPMScraper Box

<u>Weight</u> <u>Scraper</u>	<u>Percent</u> <u>Moisture</u>	<u>Watt-sec. per</u> <u>gram rock</u>	<u>Gms. rock per</u> <u>gram scraper</u>	<u>Wt. dry mater.</u> <u>per pass. gms.</u>
1140	0	0.715	1.96	2,234
1140	5	0.778	1.84	2,097
1140	10	0.782	1.818	2,072
1140	15	0.805	1.77	2,017
1140	20	0.82	1.75	1,995
1550	0	0.545	1.90	2,945
1550	5	0.61	1.74	2,698
1550	10	0.618	1.75	2,713
1550	15	0.635	1.74	2,697
1550	20	0.66	1.742	2,700
1790	0	0.57	1.72	3,079
1790	5	0.64	1.70	3,043
1790	10	0.645	1.70	3,042
1790	15	0.66	1.69	2,025
1790	20	0.68	1.69	3,022
2060	0	0.682	1.67	3,440
2060	5	0.718	1.66	3,420
2060	10	0.715	1.66	3,418
2060	15	0.72	1.65	3,400
2060	20	0.722	1.64	3,378

APPENDIX B

Rope Speed Tests at 191 FPMBox Type

<u>Weight Scraper</u>	<u>Percent Moisture</u>	<u>Watt-Sec. per Gram Rock</u>	<u>Gms. Rock Per Gram Scraper</u>	<u>Wt. Dry Mater. Per Pass, Gms.</u>
1140	0	0.64	1.538	1,753
1140	5	0.755	1.425	1,625
1140	10	0.798	1.378	1,570
1140	15	0.822	1.36	1,550
1140	20	0.83	1.34	1,528
1550	0	0.50	1.76	2,728
1550	5	0.59	1.535	2,380
1550	10	0.62	1.50	2,325
1550	15	0.62	1.46	2,262
1550	20	0.64	1.435	2,224
1790	0	0.43	1.86	3,328
1790	5	0.545	1.70	3,043
1790	10	0.60	1.705	3,051
1790	15	0.60	1.68	3,006
1790	20	0.61	1.67	2,989
2060	0	0.32	1.67	3,440
2060	5	0.425	1.51	3,110
2060	10	0.51	1.44	2,966
2060	15	0.54	1.40	2,884
2060	20	0.588	1.37	2,823

APPENDIX C

Rope Speed Tests at 252 FPMBox Type

<u>Weight Scraper</u>	<u>Percent Moisture</u>	<u>Watt-Sec. per Gram Rock</u>	<u>Gms. Rock Per Gram Scraper</u>	<u>Wt. Dry Mater. Per Pass. Gms.</u>
1140	0	0.54	1.68	1,916
1140	5	0.795	1.245	1,420
1140	10	0.84	1.260	1,436
1150	15	0.86	1.26	1,437
1140	20	0.85	1.25	1,425
1550	0	0.41	1.70	2,635
1550	5	0.48	1.475	2,286
1550	10	0.50	1.42	2,201
1550	15	0.535	1.36	2,108
1550	20	0.56	1.32	2,046
1790	0	0.31	1.71	3,060
1790	5	0.41	1.54	2,757
1790	10	0.45	1.48	2,649
1790	15	0.49	1.39	2,488
1790	20	0.52	1.36	2,434
2060	0	0.295	1.75	3,605
2060	5	0.335	1.555	3,203
2060	10	0.40	1.50	3,090
2060	15	0.43	1.42	2,925
2060	20	0.44	1.37	2,822

APPENDIX D

Rope Speed Tests at 126 FPMCrescent Type

<u>Weight Scraper</u>	<u>Percent Moisture</u>	<u>Watt-Sec. Per Gram Rock</u>	<u>Gms. Rock Per Gram Scraper</u>	<u>Wt. Dry Mater. Per Pass. Gms.</u>
1065	0	0.50	3.06	3,259
1065	5	0.62	2.56	2,726
1065	10	0.68	2.515	2,678
1065	15	0.71	2.49	2,652
1065	20	0.73	2.47	2,630
1440	0	0.525	2.22	3,197
1440	5	0.69	1.98	2,851
1440	10	0.71	1.99	2,865
1440	15	0.74	1.98	2,847
1440	20	0.76	1.98	2,848
1745	0	0.64	1.78	3,106
1745	5	0.86	1.72	3,001
1745	10	0.87	1.71	2,984
1745	15	0.92	1.69	2,949
1745	20	0.91	1.685	2,940
1950	0	0.575	1.68	3,276
1950	5	0.77	1.625	3,169
1950	10	0.80	1.62	3,159
1950	15	0.79	1.625	3,163
1950	20	0.795	1.63	3,178

APPENDIX E

Rope Speed Tests at 191 FPMCrescent Type

<u>Weight Scraper</u>	<u>Percent Moisture</u>	<u>Watt-Sec. Per Gram Rock</u>	<u>Gms. Rock Per Gram Scraper</u>	<u>Wt. Dry Mater. Per Pass. Gms.</u>
1065	0	0.51	2.63	2,803
1065	5	0.58	2.60	2,770
1065	10	0.60	2.56	2,726
1065	15	0.62	2.50	2,664
1065	20	0.625	2.48	2,642
1440	0	0.47	2.09	3,010
1440	5	0.52	1.84	2,651
1440	10	0.53	1.72	2,480
1440	15	0.54	1.68	2,421
1440	20	0.56	1.66	2,390
1745	0	0.38	1.98	3,455
1745	5	0.45	1.76	3,073
1745	10	0.475	1.70	2,968
1745	15	0.475	1.66	2,898
1745	20	0.48	1.66	2,895
1950	0	0.395	1.70	3,432
1950	5	0.48	1.61	3,141
1950	10	0.50	1.56	3,045
1950	15	0.505	1.57	3,060
1950	20	0.52	1.575	3,068

APPENDIX F

Rope Speed Tests at 252 FPMCrescent Type

<u>Weight Scraper</u>	<u>Percent Moisture</u>	<u>Watt-Sec. Per Gram Rock</u>	<u>Gms. Rock Per Gram Scraper</u>	<u>Wt. Dry Mater. Per Pass. Gms.</u>
1065	0	0.47	2.29	2,439
1065	5	0.54	2.06	2,195
1065	10	0.557	2.038	2,171
1065	15	0.565	1.98	2,110
1065	20	0.57	1.93	2,057
1440	0	0.41	1.95	2,808
1440	5	0.49	1.50	2,160
1440	10	0.53	1.49	2,146
1440	15	0.54	1.45	2,090
1440	20	0.555	1.44	2,075
1745	0	0.36	2.05	3,577
1745	5	0.45	1.58	2,757
1745	10	0.46	1.56	2,722
1745	15	0.50	1.54	2,687
1745	20	0.51	1.52	2,653
1950	0	0.325	1.78	3,471
1950	5	0.39	1.64	3,198
1950	10	0.385	1.585	3,092
1950	15	0.41	1.58	3,081
1950	20	0.43	1.565	3,052

BIBLIOGRAPHY

Books

Given, Ivan A., Mechanical Loading of Coal Underground, 1st Ed., N.Y., McGraw-Hill, 1943, pp. 247-263.

Jeppe, C. B., Gold Mining on the Witwatersrand, The Transvaal Chamber of Mines, 1946, pp. 885-895.

Peele, Robert, and Church, John A., Mining Engineer's Handbook, 3rd Ed., N.Y., Wiley, 1941, Sec. 27, pp. 11-12.

Periodicals

Carlson, R. W., General Structural Similitude: University of California Publications in Engineering, Vol. 3, No. 2, Nov. 8, 1933, pp. 141-142.

Clark, S. S., Mining Methods of the Tri-State: Engineering and Mining Journal, Vol. 144, No. 11, Nov. 1943, pp. 80-86.

Eaton, Lucien, Mechanical Loading in Metal Mines in 1929: Mining Congress Journal, Vol. 15, No. 7, July 1929, p. 536.

Eaton, Lucien, The Use of Scrapers in Metal Mines: Compressed Air Magazine, Vol. 26, May 26, 1921, pp. 10065-10075.

Fuller, Julian A., Slushing adapted to Bauxite Mining: Mining Congress Journal, January 1945, pp. 38-39.

Pierce, R. V., and Bryon, R. N., Scraping and Loading in Mines: Compressed Air Magazine, Vol. 47, No. 6, June 1942, pp. 6750-4.
Also: Mining Journal (London), Vol. 218, No. 5581, August 8, 1942, pp. 375-6.

Tolman, R. C., The Principle of Similitude: Physical Review, Vol. 4, Ser. 2, 1914, pp. 244-255.

Tolman, R. C., The Principle of Similitude and the Principle of Dimensional Homogeneity: Physical Review, Vol. 6, Ser. 2, 1915, pp. 219-233.

U. S. Government Publications

Anderson, Carl N., Mining Methods and Costs at the Interstate Zinc and Lead Company's Hartley-Mine, Tri State Zinc and Lead District, U. S. Bureau of Mines Information Circular No. 6656, p. 8., Sept. 1932.

Crane, W. R., Mining Methods and Practice in the Michigan Copper Mines, U. S. Bureau of Mines Bulletin No. 306, 1929, pp. 93-94, 154-156.

Jackson, Charles F., Underground Scraping Practice in Metal Mines, U. S. Bureau of Mines Manuscript Report No. 1, (Printed by Sullivan Machinery Company), 1933, pp. 1-88.

State Publications

Forrester, J. D. and Clayton, Austin B., A Study of Mine Scraper Buckets and Their Efficiency, Missouri School of Mines and Metallurgy, Rolla, Technical Series, Vol. 17, No. 1, March 1946, 48 p.

Johnsen, S. F., A Study of the Power Consumption of Mine Scrapers, Thesis, Missouri School of Mines and Metallurgy, 62 p.

Matson, Robert C., Scraping Practice in the Michigan Iron Mines of the Lake Superior District, Michigan College of Mining and Technology, Bulletin 1928-1929, Vol. 2, No. 4, pp. 1-75.

Van Barneveld, Charles E., Mechanical Loading in Metal Mines, Missouri School of Mines and Metallurgy Technical Bulletin Vol. 7, No. 3, 1924, pp. 210-225.

Catalogs from Manufacturers

Gardner Denver Company, Airslushers. Bulletin ASI, 1945.

Holcomb, M. D., The Original Holcomb "Westeeco" Scrapers. Catalog No. 3, (Twin City Iron Works) 1941.

Ingersoll-Rand Company, Modern Methods for Scraper Mucking and Loading. 1939, pp. 3-32.

Sauerman Bros., Inc. Crescent Scraper Buckets. Catalog 19, Section J., p. 1.

Sauerman Bros., Inc. Power Drag Scrapers. Catalog 19, Section A.

VITA

Georges J. Vigier, son of Rene F. and Marie L. (Blasine) Vigier, was born in Bastia (Corse) France on the 10th of October 1921, and is a French national.

He received the degrees of Bachelier es lettres and Bachelier es sciences from the University of Bordeaux in June 1938 and June 1939. After special studies in mathematics, physics, and chemistry, he passed successfully the competitive examination for admission at Ecole Nationale Superieure des Mines de Saint Etienne in July 1942. In November 1942 he joined the Free French Forces in North Africa. Commissioned as a lieutenant in the artillery regiment of the 2nd Moroccan Infantry Division he fought in Italy from November 1943 to July 1944. He landed then in southern France and went with the First French Army to Germany and Austria. Discharged in July 1945 he resumed his studies and graduated in June 1947 after two years spent at school instead of the three regular ones. He went then to work with Mines Domaniales de Potasse d'Alsace. By the end of January 1949 he proceeded to the United States where he held for one year an appointment as a Research Fellow at Missouri School of Mines and Metallurgy. His residence in France is 1 Rue Joseph Vogt Wittelsheim - Haut Rhin.